

NVIDIA

VANTA LT

3D GRAPHIC ACCELERATOR

MANUAL

TABLE OF CONTENTS

1. NVIDIA VANTA LT.....	2
1.1 NVIDIA Vanta LT Features.....	2
2. NVIDIA VANTA LT.....	3
2.1 Vanta LT using SGRAM 8M on Board.....	3
2.2 Vanta LT using SDRAM 8M on Board.....	3
3 Resolutions and colors supported:.....	4
4. Smart Installation.....	5
5. Manually install Windows 95 drivers.....	7
5.1 Installation and Setup.....	7
5.1.1 Windows95.....	7
5.1.2 Windows 98.....	7
5.1.3 Windows 2000.....	8
5.1.4 Windows NT4.0.....	9
5.2 How to Change Color Depth and Resolution.....	9
5.3 How to Change Refresh Rate.....	9
FCC Statement.....	11
Warning:.....	11
Trademark Acknowledgments.....	11

1. NVIDIA VANTA LT

Memory Size:

SP5200 VANTA LT : 8 MB on Board with SDRAM or SGRAM

1.1 NVIDIA Vanta LT Features

Award-winning 3D/2D performance

- 128-bit TwinN-Texture architecture
- High-performance 128-bit 2D/GUI/DirectDraw acceleration
- Fast 32-bit VGA/SVGA support
- Optimized for SIMD New Instructions and 3DNow
- High performance implementation of Direct3D and OpenGL standards
- Texture Blend support examples:

- | | |
|---------------------|----------------------|
| -Multi-texture | -Reflection maps |
| -Bump map | -Detail texture |
| -Texture modulation | -Environmental maps |
| -Light maps | -Procedural textures |

- 24-bit or 16-bit Z buffer (floating point or integer)

- 8-bit stencil buffer

- Anti-aliasing, full scene, order independent

High quality video playback

- Full-screen, full-frame DVD playback (need S/W DVD player program)
- Video acceleration for DirectShow, MPEG-1, MPEG-2, and Indeo
- Back-end hardware video scaling for video conferencing and playback
- Hardware color-space conversion (YUV 4:2:2 and 4:2:0)
- Multi-tap X and Y filtering
- Per-pixel color keying
- Multiple video windows with hardware color space conversion and filtering
- DVD sub-picture alpha-blended compositing

Robust system interface

- AGP 2x interface (AGP 2.0)
- 64-bit frame buffer interface, supporting up to 8MB of SDRAM/SGRAM

Software drivers support

- Windows2000, Windows NT4.0 display drivers
- Windows 98 and 95 display drivers
- OpenGL ICD for Windows 2000, Windows NT4.0, Windows 98, and Windows95

2. NVIDIA VANTA LT

2.1 Vanta LT using SGRAM 8M on Board

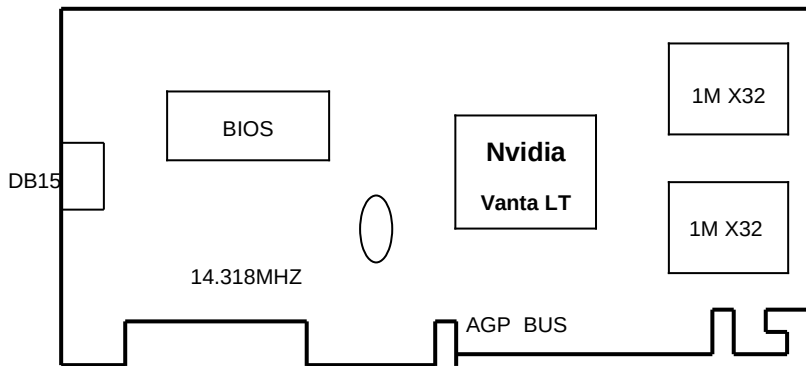

2.2 Vanta LT using SDRAM 8M on Board

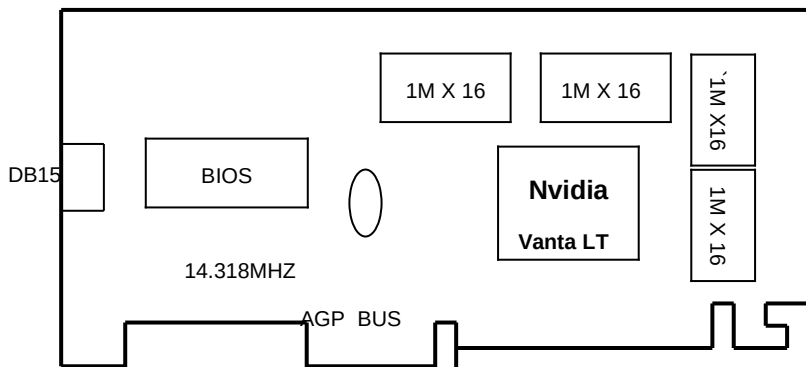

3 Resolutions and colors supported:

	Bits Per pixel	Memory Req. (MB)	Refresh Rates (HZ)
640*480	8	1MB	60/70/72/75/85/100/120/140/144/150
	16	1MB	60/70/72/75/85/100/120/140/144/150
	32	2MB	60/70/72/75/85/100/120/140/144/150
800*600	8	1MB	60/70/72/75/85/100/120/140/144
	16	1MB	60/70/72/75/85/100/120/140/144
	32	2MB	60/70/72/75/85/100/120/140/144
960*720	8	1MB	60/70/72/75/85/100/120
	16	1MB	60/70/72/75/85/100/120
	32	2MB	60/70/72/75/85/100/120
1024*768	8	1MB	60/70/72/75/85/100
	16	2MB	60/70/72/75/85/100
	32	4MB	60/70/72/75/85/100
1152*864	8	1MB	60/70/72/75/85/100
	16	2MB	60/70/72/75/85/100
	32	4MB	60/70/72/75/85/100
1280*1024	8	2MB	60/70/72/75/85
	16	4MB	60/70/72/75/85
	32	8MB	60
1600*1200	8	2MB	60/70/72/75
	16	4MB	60/70/72/75
	32	8MB	60/70/72/75
1920*1080	8	4MB	60/70/72/75
	16	8MB	60/70/72/75
	32	16MB	60/70/72
1920*1200	8	4MB	60/70/72/75
	16	8MB	60/70/72/75
	32	16MB	60

4. Smart Installation

For Windows 95 、 Windows 98 、 Windows 2000 、 Windows NT

4.1 Put the DRIVERS CD in your CD-ROM

4.2 Click the **Driver installation**



4.3 If everything goes fine, screen will show **Confirm Installation** window.

Then Select the **OK**

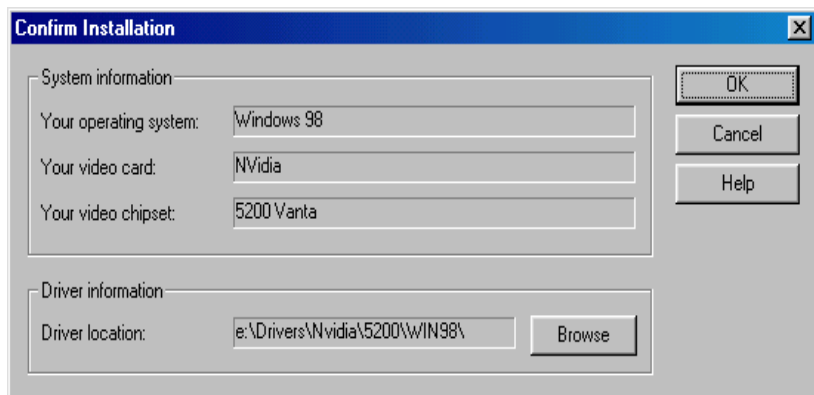

- 4.4 Now appears the **Driver Confirmation** window
Select the **Install**

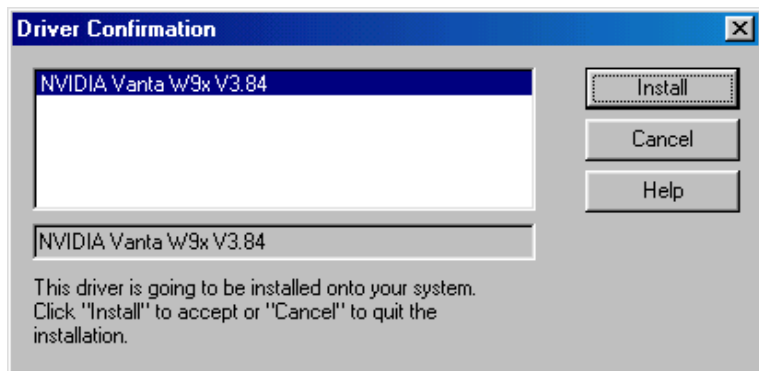

- 4.5 Then restart your computer.

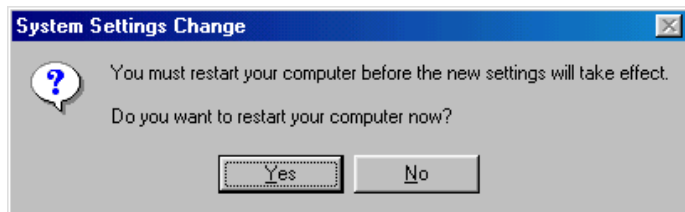

5. Manually install Windows 95 drivers

5.1 Installation and Setup

5.1.1 Windows95

The Windows setup program installs and modifies all of the necessary files. Follow these steps to install the Windows 95 drivers.

- Insert the DISC (CD Title Driver).
- Select **Control Panel** from **My Computer** group.
- Select the **Display** icon
- Double-click on the **Display** icon in the Setting -> **Control Panel** folder. You can also click the right mouse button anywhere on the desktop and select the Properties option from the pop-out menu.
- Click the **Settings** tab.
- Click the **change** Display Type button.
- Click the **Have Disk** button.
- Change directories and Select **NV4agp .inf**
Disc (CD Title) is **E:\drivers\Nvidia\5200\WIN9x (Vanta LT:5200)**

Note: "E:"-> CD Drive "Nvidia"-> VGA chip brand name "5200"-> VGA model name

- Select AGP driver from the list and click the **OK** button. If a message stating that one or more driver files is older than the files on the system respond **YES** to overwrite the files.
- Click the Close button and Apply button, and restart your computer.

5.1.2 Windows 98

The Windows setup program installs and modifies all of the necessary files. Follow these steps to install the Windows 98 drivers.

- Insert the DISC (CD Title Driver).
- Select **Control Panel** from **My Computer** group.
- Select the **Display** icon
- Double-click on the **Display** icon in the Setting -> **Control Panel** folder. You can also click the right mouse button anywhere on the desktop and select the Properties option from the pop-out menu.
- Click the **Settings** tab.
- Then show **[Unknown Device.] Properties** tab
Select **Adapter**
- Then show **Standard PCI Graphics....** tab
Select **Change**
- Then show **Update Device** tab
Select **Next**
- Then show **Update Device** tab
Select **Search for a better.....**
Then select **Next.**
- Then show **Update Device** tab
If the **Specify a location** is wrong
Please select **Brows**
- Then show **Browse for Folder** tab

Select **E:\drivers\ Nvidia\5200\win9x (Vanta LT: 5200)**

Disc (CD Title) is **E:\drivers\ Nvidia\5200\win9x**

Note: "E:"-> CD Drive "Nvidia"-> VGA chip brand name "5200"-> VGA model name
Then select **OK**

- Then show **Update Device Driver Wizard** tab
Select **CD-ROM driver**
Click the **Specify a locator**, if right
Then select **Next**
- Then show **Update Device Driver Wizard** tab
Select **Next**
- Then show **Update Device Driver Wizard** tab
Select **Finish**
- Then show **System Settings Change** tab
Select **OK**

5.1.3 Windows 2000

First time install drivers under windows2000

1. When system boot up, system will prompt find new device. Suppose the device is VGA, now system will find the default drivers for you.
2. If you want to install our drivers along with the SP5200LT pack. Please put the drivers CD in your CDROM drive. If now shows SmartInstall window, please click **EXIT** button to quit.
3. Drivers for windows2000 are located at \2000drv\nvidia\win2000 or \drivers\nvidia\5200\win2000
4. If the drivers is very new may not certified by Microsoft, if so, system will prompt you the drivers do not have "digital signature", still you can force to install.
5. Follow on screen instructions will finish the installation.

The following steps describe how to update Windows2000 display drivers

1. Place the Disc (CD Title) into CDROM Drive. If now shows SmartInstall window, please click **EXIT** button to quit
2. Right click mouse button on Desktop Area, now shows a sub menu window. Please select **Properties**.
3. Now come up **Display Properties** window, please select **Settings** on the top.
4. Select **Advanced**
5. Select **Adapter**.
6. Select **Change**
7. Now comes up a update drivers wizard window. Please follow the on screen instruction.
8. Please specify the drivers location at your CDROM letter:\2000drv\nvidia\win2000 or \drivers\nvidia\5200\win2000 or the directory where you put your drivers
9. Select **Install** and click "**YES**" when the Installing Driver dialog box appears. If the drivers is very new may not certified by Microsoft, if so, system will prompt you the drivers do not have "digital signature", still you can force to install.

A message appears stating that drivers were successfully installed. Click **OK**. Another message appears stating that the driver could not be restarted dynamically. Restart Windows2000 to run the new driver. Click **OK**.

5.1.4 Windows NT4.0

The following steps describe how to install Windows NT4.0 display drivers

1. Select **Control Panel** from the **Main** group.
2. Select the **Display** icon.
3. Select **Change Display Type**.
4. Select **Change** from the **Adapter Type** area.
5. Select **Other**.
6. Place the Disc (CD Title) into Driver. Click **OK**.
7. Select **Install** and click "**YES**" when the Installing Driver dialog box appears.
8. When the Windows NT **Setup** dialog box appears select CDROM, and click "**Continue**".

A message appears stating that drivers were successfully installed. Click **OK**. Another message appears stating that the driver could not be restarted dynamically. Restart **Windows NT** to run the new driver. Click **OK**.

5.2 How to Change Color Depth and Resolution

1. Make sure that you have installed windows95/98/2000 Driver
2. Click on the **Start** box in the lower left corner and proceed to **Control Panel**.
3. Inside the **Control panel** group , click on **Display** icon to open the **Display Properties** folder and select the **Setting table**
4. Click on the pull-down arrow from the **Color** palette area to select color depth or adjust the sliding bar to either **Less** or **More** from the **Desktop area**
5. Select **OK** to restart **WINDOWS95** and new color depth or the new resolution takes effect.

5.3 How to Change Refresh Rate

1. Make sure that you have installed windows95/98 Driver. Click on the **Start** box in the lower left corner and proceed to **Setting, Control Panel**
2. Inside the **Control panel** group , click on **Display** icon to open the **Display Properties** folder and choose **Settings** click the **Advance Settings** choose **Adapter**
3. Click on the **Refresh Rate** sub window to change refresh rate
4. Select **OK** and new refresh rate takes effect

Note: If your monitor is not Branded or Plug&Play, you will only see Adapter default and optimal.or even you can not see the refresh rate selection menu; Please contact your monitor supplier to get right or compatible drivers for your monitor. Otherwise you can not select the refresh rate you wanted.

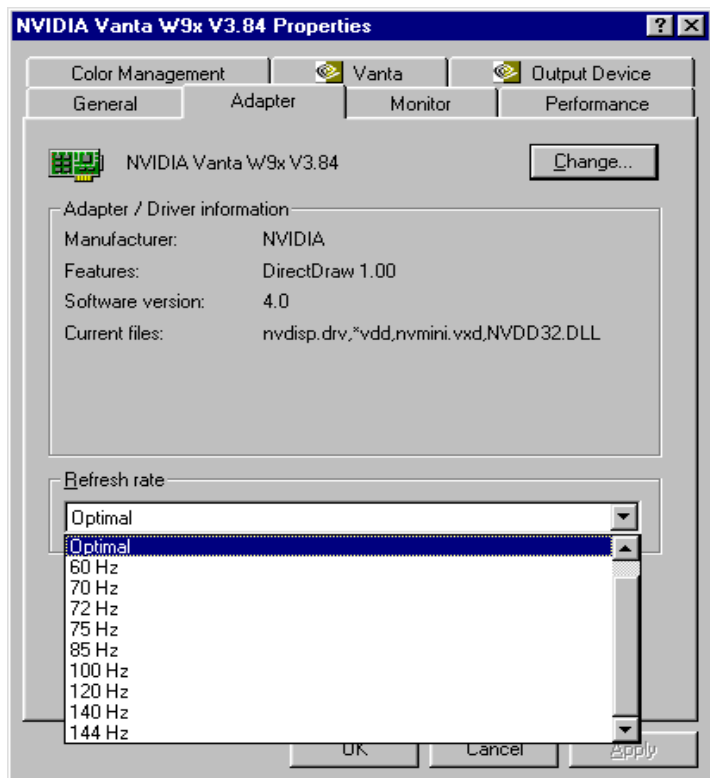

- Refresh Rate default is Optimal.
- If you change Refresh Rate from Optimal to another , you may be need to restart Windows 95 or 98

FCC Statement

This device complies with part 15 of the FCC Rules. Operation is subject to the following two conditions: (1) this device may not cause harmful interference. (2) this device must accept any interference received, including interference that may cause undesired operation

Warning:

Note: This equipment has been tested and found to comply with the limits for a Class B digital device, pursuant to Part 15 of FCC Rules. These limits are designed to provide reasonable protection against harmful interference in a residential installation. This equipment generates, uses and can radiate radio frequency energy and, if not installed and used in accordance with the instructions, may cause harmful interference in to radiate communications. However, there is no guarantee that interference will not occur in a particular installation. If this equipment does cause harmful interference to radio or television reception, which can be determined by turning the equipment off and on, the user is encouraged to try to correct the interference by one or more of the following measures:

- Reorient or relocate the receiving antenna
- Increase the separation between the equipment and receiver.
- Connect the equipment into an outlet on a circuit different from that to which the receiver is connected.
- Consult the dealer or an experienced radio/TV technician for help.

Notice:

(1) An Unshielded-type power cord is required in order to meet FCC emission limits and also to prevent interference to the nearby radio and television reception. It is essential that only the supplied power cord be used.

(2) Use only shielded cables to connect I/O devices to this equipment.³

(3) Changes or modifications not expressly approved by the party responsible for compliance could void the user's authority to operate the equipment.

Trademark Acknowledgments

All brand names and trademarks are the property of their owners.