

# XWAVE3000 PCI Sound Card

---

## Configuration and Hardware USER MANUAL

January 1999

---

## TABLE OF CONTENTS

<b>1. DESCRIPTION.....</b>	<b>2</b>
1.1 FEATURES.....	2
1.2 CARD FIGURE.....	3
1.3 CONNECTORS.....	3
1.3.1 External Connectors:.....	3
1.3.2 Internal Connectors:.....	3
1.3.3 Audio Connectors:.....	4
1.3.4 Audio Output Jumper Settings for JP1:.....	4
<b>2. HARDWARE INSTALLATION.....</b>	<b>5</b>
2.1 HANDLING THE PCI SOUND CARD.....	5
2.2 INSTALLING THE PCI SOUND CARD.....	5
<b>3. SOFTWARE INSTALLATION.....</b>	<b>6</b>
3.1 DEVICE DRIVER INSTALLATION UNDER WINDOWS® 95OSR2.....	6
3.2 DEVICE DRIVER INSTALLATION UNDER WINDOWS® 98.....	6
3.3 APPLICATION INSTALLATION UNDER WINDOWS® 95 OSR2/98.....	6
3.4 DEVICE DRIVER INSTALLATION UNDER WINDOWS® NT4.0.....	6

## 1. DESCRIPTION

This is a new audio adapter that provides the next generation of PCI audio performance to the PC market. The adapter not only meets the new demands of advanced PC audio applications but also enables the integration of a complete multimedia subsystem on a single adapter. The adapter functionality and interfaces are compliant with all major industry standards, including the SoundBlaster Compatible, PC'97, Windows Direct Sound, Windows Sound System and PCI 2.1 bus specification.

### 1.1 Features

#### Chipset

- QS3000A + AC '97 CODEC
- 100 QFP Package

#### System Interface

- High Performance 32 bit PCI Master/Slave Interface PCI 2.1 compliant and scatter-and-gather capability.

#### Hardware Interface

- Analog/Digital Joystick Interface (Direct Input Support)
- S/PDIF Digital Output Support
- EEPROM Interface
- Support APM, PPMI, ACPI and CLKRUN protocols

#### Wavetable Synthesizer

- Includes H/W OPL-Compatible FM synthesis hardware
- High quality 20-voice, 4-operator
- Professional 128 Voices Software Wavetable

#### Compatibility

- 100% Sound Blaster Pro legacy audio compatible on PCI (DDMA, PC/PCI, Serial IRQ)

#### Software Compatibility

- Fully Sound Blaster and Sound Blaster Pro compatible
- Direct Sound compatible

#### Software Support

- Windows® 95, Windows® 98 and Windows® NT4.0.

#### Amplifier

- 2 Watt per channel output

## 1.2 Card Figure

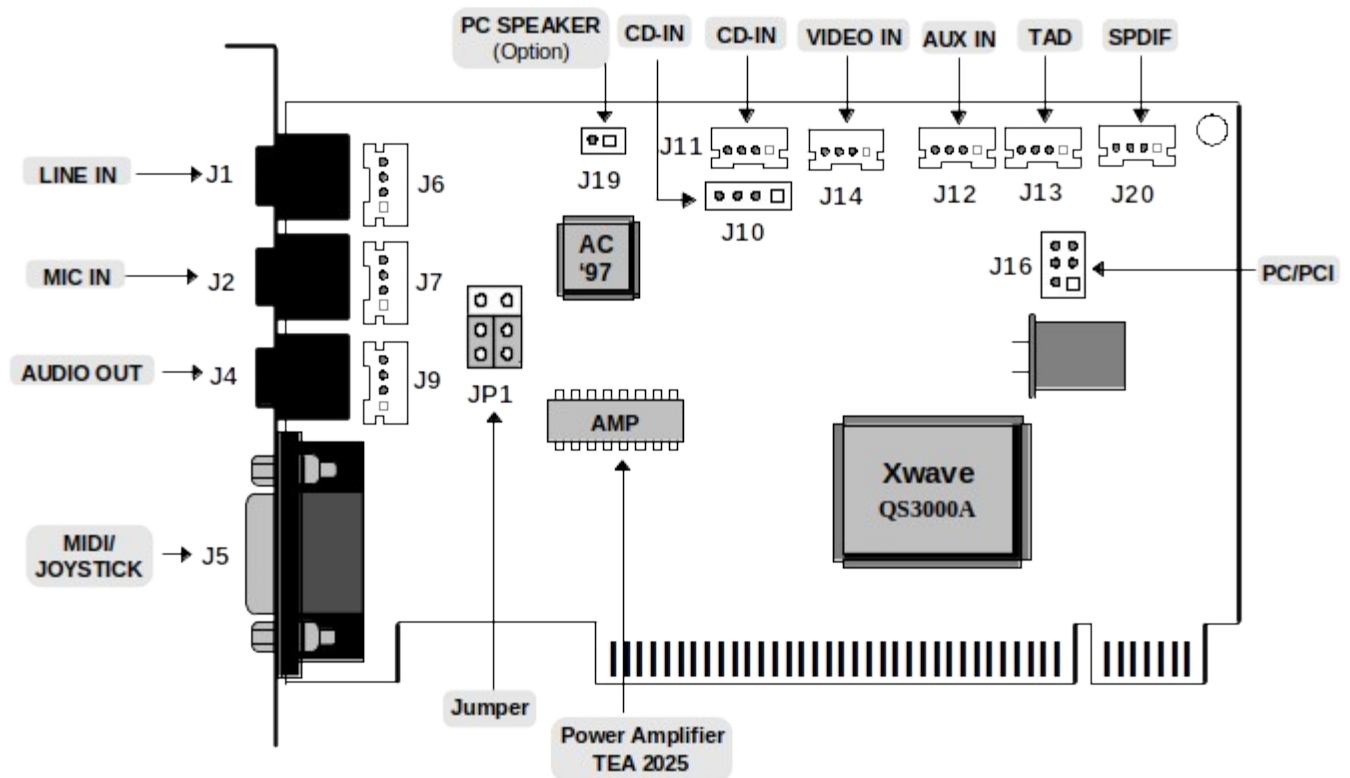

## 1.3 Connectors

This PCI Sound Card includes up to eight internal connectors, three external Jack Ports, one external MIDI/ Joystick connector, one VIDEO connector, one VOICE Modem connector, and one PC/PCI Legacy AUDIO SIDEBAND SIGNAL connector.

### 1.3.1 External Connectors:

- J1:..... ∅ 3.5mm Phone Jack for **LINE IN**
- J2:..... ∅ 3.5mm Phone Jack for **MIC IN**
- J4:..... ∅ 3.5mm Phone Jack for **AUDIO OUT**
- J5:..... Connector for **MIDI/JOYSTICK**

### 1.3.2 Internal Connectors:

- J6:..... Internal connector for **LINE IN** (optional)
- J7:..... Internal connector for **MIC IN** (optional)
- J9:..... Internal connector for **AUDIO OUT** (optional)
- J10:..... Connector for **CD-AUDIO IN** (Base Pin)
- J11:..... Connector for **CD-AUDIO IN** (JST)
- J12:..... Connector for **AUX IN**
- J13:..... Connector for **TAD/VOICE MODEM**
- J14:..... Connector for **VIDEO IN**
- J16:..... Connector for **PC/PCI Legacy Audio SIDEBAND SIGNAL**
- J19:..... Connector for **PC SPEAKER** (optional)
- J20:..... Connector for **SPDIF** (optional)
- JP1:..... Jumper for switching between **SPEAKER OUT/LINE OUT**



1.3.3 Audio Connectors:

- J10: CD-Audio**

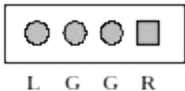

L G G R

L: LEFT CHANNEL SIGNAL  
G: GROUND  
R: RIGHT CHANNEL SIGNAL
- J11: CD-Audio**

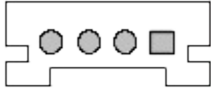

R G L G

L: LEFT CHANNEL SIGNAL  
G: GROUND  
R: RIGHT CHANNEL SIGNAL
- J12: AUX In**

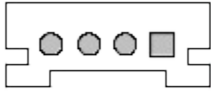

R G G L

L: LEFT CHANNEL SIGNAL  
G: GROUND  
R: RIGHT CHANNEL SIGNAL
- J13: TAD/Voice Modem**

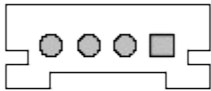

4 3 2 1

1 MONO OUT  
2 GROUND  
3 GROUND  
4 PHONE IN
- J14: VIDEO IN**

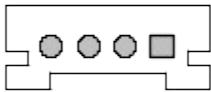

L G G R

L: LEFT CHANNEL SIGNAL  
G: GROUND  
R: RIGHT CHANNEL SIGNAL
- J16: PC/PCI**

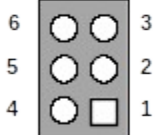

6 5 4 3 2 1

1 PCGNT #  
2 N.C.  
3 GROUND  
4 GROUND  
5 PCREQ #  
6 SERIRQ #
- J19: PC BEEP**



2 1

1 PC SPEAKER OUT  
2 +5V
- J20: SPDIF**



4 3 2 1

1 SPDIF OUTPUT  
2 GROUND  
3 GROUND  
4 SPDIF OUTPUT

1.3.4 Audio Output Jumper Settings for JP1:

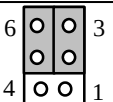
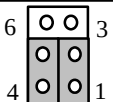
Audio	Setting
SPEAKER OUT with Power Amplifier (Default)	
LINE OUT without Power Amplifier	

---

## 2. HARDWARE INSTALLATION

### 2.1 Handling the PCI Sound Card

**WARNING:** Static electricity can damage your equipment. Do not take the card out of its static protective bag until you are ready to work with it.

Follow these precautions when handling the card:

- Before you open the static protective bag, touch it to a metal expansion slot cover on the back of your computer. This drains static electricity from the package and from your body.
- Do not touch any exposed printed circuitry after opening the package.
- Keep other people from touching the card. They might have a static-electricity build-up.
- Limit your movement. Movement causes a build-up of static electricity.

- **Installing the PCI Sound Card**

**Step 1.** Turn off the system and all peripheral devices.

**Step 2.** Disconnect the power cord and all peripheral devices from the system.

**Step 3.** Remove the system cover and identify an unused PCI slot.

**Step 4.** Unscrew the slot cover plate, plug in the PCI Sound Card, and tighten it with the screw.

**Step 5.** If you have speakers or amplifiers, plug the cable into the **J4** Jack on the back of the Sound Card.

**WARNING!** To avoid temporary or permanent hearing loss or impairment due to unexpected noise or static, always hold your headphones away from your ears before turning on the computer. You should also lower your speaker's volume before testing.

**Step 6.** Depending on what type of CD Audio cable you have connect **J10** or **J11** on the Sound Card and the Audio output at the back of the CD-ROM drive. Make sure pin 1 of **J10** or **J11** is connected to the leftmost pin of the CD-ROM Audio output.

**Step 7.** Put back the system cover, reconnect the system power cord and all peripheral devices. Check and make sure all connections are correct before you turn on the system.

**NOTE:** *If you want to listen to the sound of DOS Games and your motherboard supplies the respective connector, please connect the cable for the PC/PCI Legacy Audio Sideband Signal to J16 on the PCI Sound Card.*

### **3. SOFTWARE INSTALLATION**

#### **3.1 Device Driver Installation Under Windows® 95OSR2**

- 1.) After you have installed the PCI Sound Card, restart your Microsoft® Windows® 95 OSR2 operating system.
- 2.) An "Update Device Driver Wizard" dialog box appears, showing you that a PCI Multimedia Audio Device has been detected by the system. Click on "Next" to continue.
- 3.) The "Update Device Driver Wizard" dialog box informs you that the system cannot find the device driver. Please insert your CD-title into your CD-ROM drive. Click on "Other Locations...".
- 4.) Assuming your CD-ROM drive is D, type in the "Select Other Location" dialog box the command **D:\Win95**. Click on OK.
- 5.) An "Update Device Driver Wizard" dialog box informs you that the system has found the "XWAVE3000 PCI Sound" device driver. Click on "Finish".
- 6.) Follow the on-screen instructions and you should be able to install the device driver easily.

#### **3.2 Device Driver Installation Under Windows® 98**

- 1.) After you have installed the Sound Card, restart your Microsoft® Windows® 98 operating system.
- 2.) The "Add New Hardware Wizard" dialog box displays the message "PCI Multimedia Audio Device". Click on "Next".
- 3.) Choose the option "Search for the best driver for your device" and click on "Next".
- 4.) Choose "Specify a location". Insert the CD-title into your CD-ROM drive. Assuming your CD-ROM drive is E, type **E:\Win95** and click on "Next".
- 5.) Follow the on-screen instructions and you should be able to install the device driver easily.

#### **3.3 Application Installation Under Windows® 95 OSR2/98**

- 1.) Start up your Microsoft® Windows® 95/98 operating system.
- 2.) Click on the START button and choose the RUN item.
- 3.) Please, insert the CD-title into your CD-ROM drive. Assuming your CD-ROM drive is E, type **E:\PLAYER\SETUP.EXE** in the command line of the RUN dialog box.
- 4.) Click on OK and follow the on-screen instructions. The Software application will be installed onto your system.

#### **3.4 Device Driver Installation Under Windows® NT4.0**

- 1.) Start up your Microsoft® Windows® NT4.0 operating system and log on as ADMINISTRATOR.
- 2.) Click on "Start"->"Settings"->"Control Panel" and double-click on the "Multimedia" icon in the "Control Panel" program group.
- 3.) A "Multimedia Properties" dialog box will appear. Please click on the "Devices" tab, then on the "ADD" push button
- 4.) Please select "Unlisted or Updated driver" and click on OK in the "ADD" dialog box.

- 5.) The system will prompt you to specify the path of the driver in the "Install Driver" dialog box. Please specify the path as **E:\WinNT**, assuming your CD-ROM drive is E. Insert the XWAVE3000 driver CD-title into your CD-ROM drive and click on the OK push button to continue installing the driver.
- 6.) An "Add Unlisted or Updated Driver" dialog box will appear to inform you that the "XWAVE3000 PCI Audio Device" driver has been found. Please click on OK to continue.
- 7.) The "XWAVE3000 PCI Audio Device" driver has been added. You may now restart the computer so the new driver can take effect.

NOTE: The control panel of the application software "XWAVE Multimedia Deck" looks best when applying color palette "256 Color/High Color (16 bit)/True Color".
--

A20-0038-116  
Nov.5,1999(v5)