

# PX915P-2V

## **Copyright**

All rights are reserved. No part of this publication may be reproduced, transmitted, transcribed, stored in a retrieval system or translated into any language or computer language, in any form or by any means, electronic, mechanical, magnetic, optical, chemical, manual or otherwise, without the prior written permission of the company. Brands and product names are trademarks or registered trademarks of their respective companies.

The vendor makes no representations or warranties with respect to the contents herein and especially disclaim any implied warranties of merchantability or fitness for any purpose. Further the vendor reserves the right to revise this publication and to make changes to the contents herein without obligation to notify any party beforehand. Duplication of this publication, in part or in whole, is not allowed without first obtaining the vendor's approval in writing.

## **Trademark**

All the trademarks or brands in this document are registered by their respective owner.

## **Disclaimer**

We make no warranty of any kind with regard to the content of this user's manual. The content is subject to change without notice and we will not be responsible for any mistakes found in this user's manual. All the brand and product names are trademarks of their respective companies.

## **FCC Compliance Statement**

This equipment has been tested and found to comply with the limits of a Class B digital device, pursuant to Part 15 of the FCC Rules. These limits are designed to provide reasonable protection against harmful interference in a residential installation. This equipment generates, uses and can radiate radio frequency energy and, if not installed and used in accordance with the instructions, may cause harmful interference to radio communications. Operation of this equipment in a residential area is likely to cause harmful interference in which case the user will be required to correct the interference at his own expense. However, there is no guarantee that interference will not occur in a particular installation.

## **CE Mark**

The device is in accordance with 89/336 ECC-ENC Directive.

Ver: EG101

**PX915P-2V**  
Intel® 915P & ICH6  
Support Socket 775  
Intel® Pentium® 4 Prescott Processor

# User Manual

**Enabling the Hyper-Threading Technology, your computer system is required to have components as the following:**

- ❖ **CPU:** An Intel® Pentium® 4 Processor with HT Technology
- ❖ **Chipset:** An Intel® Chipset that supports HT Technology
- ❖ **BIOS:** A BIOS that supports HT Technology must be enabled
- ❖ **OS:** An operating system that supports HT Technology

**For more information on Hyper-Threading Technology, go to:**  
<http://www.intel.com/info/hyperthreading>

**Dimensions (ATX form-factor):**

- ❖ 244mm x 295mm ( W x L )

**Operating System:**

- ❖ Windows® 2000/ XP

## Things You Have To Know

- The images and pictures in this manual are for reference only and may vary from the product you received depending on specific hardware models, third party components and software versions.
- This mainboard contains very delicate IC chips. Always use a grounded wrist strap when working with the system.
- Do not touch any IC chip, lead, connector or other components.
- Always unplug the AC power when you install or remove any device on the mainboard or when configuring pins and switches.

## Packing List

- ❖ PX915P-2V Mainboard
- ❖ IDE Cable
- ❖ FDD Cable
- ❖ SATA Cable
- ❖ I/O Bracket
- ❖ SPDIF Card (optional)
- ❖ ABS Card (optional)
- ❖ Mainboard Setup Driver CD
- ❖ Mainboard User Manual CD
- ❖ Mainboard Quick Installation Guide

## Symbols



Attention- Important Information



Follow the procedures below...



Troubleshooting Tips



Refer to other sections in this manual...

# Table of Contents

<b>CHAPTER 1. GETTING STARTED .....</b>	<b>1</b>
INTRODUCTION.....	1
SPECIFICATION .....	2
CONFIGURATION .....	5
Layout of PX915P-2V .....	5
HARDWARE INSTALLATION .....	6
CPU Processor Installation.....	6
Memory Installation .....	7
Back Panel Configuration.....	9
Connectors.....	11
Front Panel Headers.....	12
Headers & Jumpers.....	13
Audio Configuration.....	15
Slots .....	17
Power Supply Attachments.....	17
<b>CHAPTER 2. BIOS SETUP.....</b>	<b>18</b>
INTRODUCTION.....	18
MAIN MENU .....	20
ADVANCED BIOS FEATURES .....	21
PERIPHERALS.....	27
POWER MANAGEMENT.....	31
HARDWARE MONITOR.....	34
DEFAULTS .....	35
EXIT MENU.....	36
<b>CHAPTER 3: SOFTWARE SETUP.....</b>	<b>37</b>
SOFTWARE LIST .....	37
SOFTWARE INSTALLATION.....	37
<b>CHAPTER 4: TROUBLESHOOTING.....</b>	<b>39</b>
APPENDIX I: SUPER 5.1 CHANNEL AUDIO EFFECT SETUP.....	42
APPENDIX II: ABS (ALBATRON BIOS SECURITY) CARD SETUP .....	43

# **Chapter 1. Getting Started**

## **Introduction**

Thanks for choosing PX915P-2V Mainboard. It is based on Intel® 915P Northbridge chipset and Intel® ICH6 Southbridge chipset. It supports Intel® Pentium® 4 Prescott Processor with FSB (Front Side Bus) 800 MHz.

The PX915P-2V provides four DIMM (Dual In-Line Memory Modules) sockets which allowing you to install 240-pin, unbuffered non-ECC, DDRII 400/ DDRII 533 SDRAMs. It also supports Dual Channel Technology and allows you installing a total memory capacity of 4 GB.

This mainboard provides two PCI-E x16 interface slots and which up to x16 and x4 modes can be supported individually. It is recommended that insert a graphics card onto the PCI-E x16 slot, and insert an expansion card which the interface is capable for PCI-E x16 specification onto the other slot, PCI-E1. This mainboard can support up to four separated monitors displaying at the same time. In addition, two PCI slots come with this mainboard and are capable for using with expansion cards.

The PX915P-2V provides one floppy disk drive connector that can be used with 360KB/720KB/1.2MB/1.44MB/2.88MB drives. It also has one IDE connector for IDE hard drives supporting Ultra ATA 66/100/133. Moreover, the onboard comes with Serial ATA feature, four SATA connectors which the interfaces can provide up to 150 Mbps transmission speeds.

The onboard AC' 97 sound codec supports high quality 6-channel audio play (Super 5.1 Channel Audio Effect) < **See Appendix I** > and supports the Sony/Philips Digital Interfaces (SPDIF) output/input functionality.

There are maximal eight USB2.0/ 1.1 ports can be set on this mainboard.

The PX915P-2V also comes with an onboard 10/100 Mbps Ethernet LAN chip (1GBLAN is optional). There is a LAN port on the case back panel that you can directly plug into an Internet cable.

In addition, this mainboard supports the ABS (Albatron BIOS Security) card (Optional), which is a small circuit board inserted onto the mainboard providing full backup BIOS functionality in case of BIOS failure or damage during the BIOS flash < **See Appendix III** >.

All the information (including hardware installation and software installation) in this manual are for reference only. The contents in this manual may be updated without notice. The company will not assume any responsibility for any errors or mistakes within.

## **Mainboard PX915P-2V**

### **Specification**

#### **CPU:**

- ❖ Support Socket 775 Pentium® 4 Prescott Processor
- ❖ Support Hyper-Threading Technology
- ❖ Support FSB (Front Side Bus) 800 MHz

#### **Chipset:**

- ❖ Northbridge Chipset – Intel® 915P
- ❖ Southbridge Chipset – Intel® ICH6
- ❖ I/O Controller – Winbond® W83627THF
- ❖ AC' 97 Sound Codec – Realtek® ALC655
- ❖ Mb LAN Controller – Realtek® RTL 8100C
- ❖ Gb LAN Controller – Realtek® RTL 8110S (Optional)

#### **Memory:**

- ❖ Four DIMM sockets
- ❖ Supports unbuffered non-ECC, DDRII 400/ DDRII 533 SDRAM
- ❖ Supports a total memory capacity of up to 4GB
- ❖ Supports Dual Channel data bus

#### **Slots:**

- ❖ Two PCI-Express x16 interface slots for dual graphics cards:
  1. PCI-E x16 slot: Supports up to x16 mode
  2. PCI-E1 slot: Supports up to x4 mode
- ❖ Two PCI interface slots for expansion cards

#### **FDD Connector:**

- ❖ One floppy disk drive connector, supports up to two FDDs
- ❖ Supports 360KB/720KB/1.2MB/1.44MB/2.88MB

## **Mainboard PX915P-2V**

### **IDE Connector:**

- ❖ One IDE connectors, support up to four IDE devices
- ❖ Supports Ultra ATA 33/ 66/100/133
- ❖ Supports high capacity hard disk drives

### **Serial ATA Connector:**

- ❖ Four SATA connectors, support up to four SATA HDDs can be set up
- ❖ Supports SATA 1.0 specification and with 150MBps transmission speeds

### **Onboard AC' 97 Sound Codec:**

- ❖ High performance Codec with high S/N ratio (>90 db)
- ❖ Compliant with AC' 97 2.3 specification
- ❖ Supports 6 channel playback capability (Super 5.1 Channel Audio Effect)
- ❖ Supports 3D stereo enhancement
- ❖ Supports Sony/ Philips Digital Interfaces (S/PDIF) functionality

### **Onboard LAN Chip:**

- ❖ 10/100 Mbps Ethernet LAN supported (1GbLAN is optional)

### **I/O facility Connectors**

- ❖ One multi-mode Parallel Port is capable to support as the following:
  1. Standard & Bi-direction Parallel Port
  2. Enhanced Parallel Port (EPP)
  3. Extended Capabilities Port (ECP)
- ❖ One serial port
- ❖ One PS/2 mouse port and one PS/2 keyboard port
- ❖ One GAME PORT header (Optional) and one SPDIF header are able to connect external devices

### **USB Ports:**

- ❖ Four onboard USB 2.0/ 1.1 ports
- ❖ Two front USB headers come with this mainboard, and support a maximum of four additional USB ports to be set

## **Mainboard PX915P-2V**

### **BIOS:**

- ❖ Phoenix-Award™ BIOS
- ❖ Support APM1.2
- ❖ Support ACPI2.0 power management

### **Green Function:**

- ❖ Supports Phoenix-Award™ BIOS power management function
- ❖ Supports system-wake-from-power-saving-mode by keyboard or mouse touching

### **Hardware Monitor Function:**

- ❖ Monitors CPU/ Chassis Fan Speed
- ❖ Monitors CPU and system temperature
- ❖ Monitors system voltages

### **Watch Dog Timer:**

This function is used for detecting the system hangs during the POST stage due to conflicts resulting from changing the system BIOS settings. Once the problem is detected, the system will reset the configurations and reboot the system within five seconds.

### **ABS (Albatron BIOS Security):**

- ❖ Supports ABS card (optional)
- ❖ Supports BIOS backup

**Mainboard PX915P-2V**

**Configuration  
Layout of PX915P-2V**

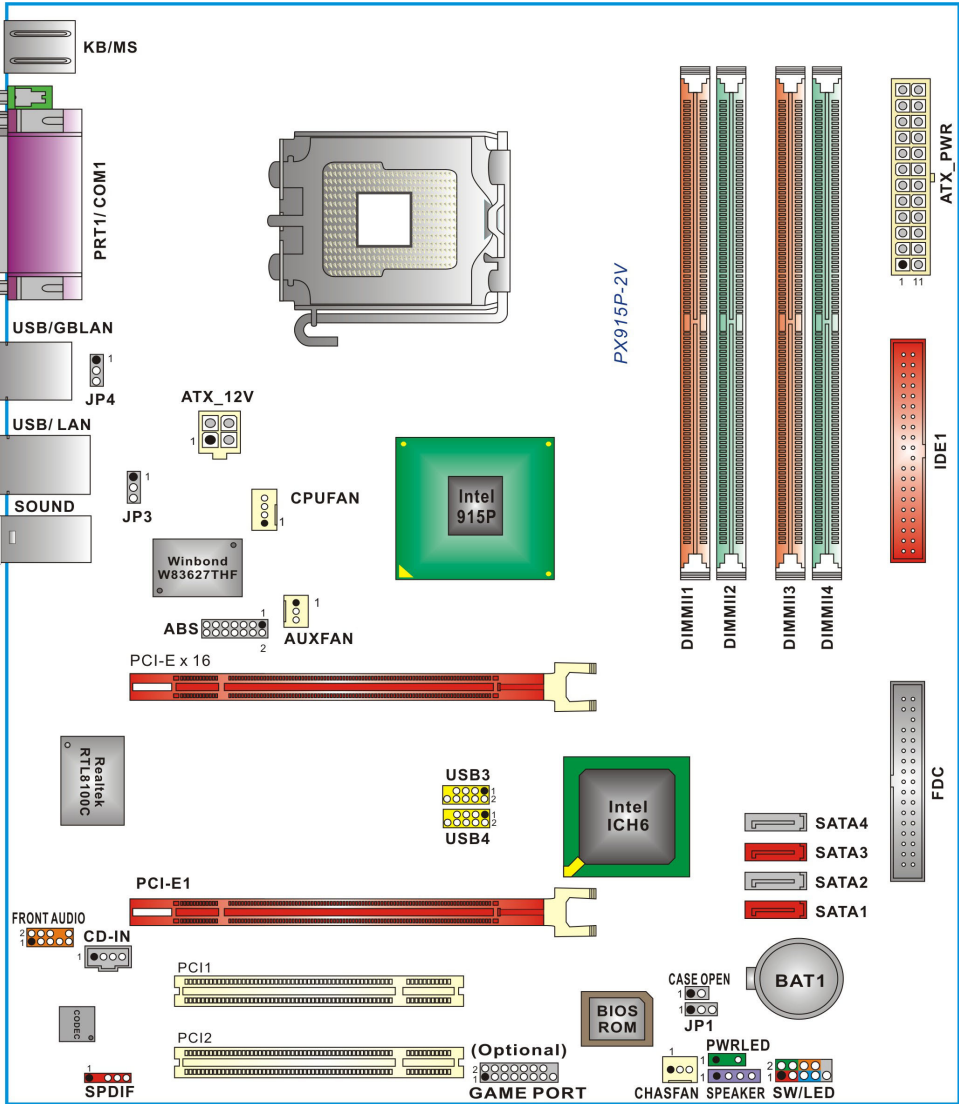

## Hardware Installation

This section will assist you in quickly installing your system hardware. Wear a wrist ground strap before handling components. Electrostatic discharge may damage the system's components.

### CPU Processor Installation

This mainboard supports Intel® Pentium® 4 Prescott Processors using a Socket 775. Before building your system, we suggest you to visit the Intel website and review the processor installation procedures. <http://www.intel.com>

#### CPU Socket 775 Configuration Steps:

1. Locate the CPU socket 775 on your mainboard and nudge the lever away from the socket as shown. Then lift the lever to a 140-degree angle (A). Next, lift up the iron cover (B).

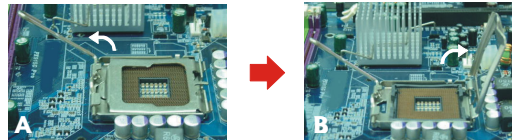

2. There are 2 distinctive marks located near the corners of the socket on the same side as the lever as shown (C). Match these marks with the marks on the CPU and carefully lower the CPU down onto the socket (D).

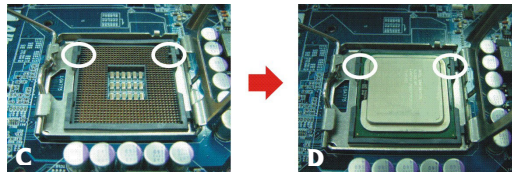

3. Replace the iron cover and then lower the lever until it snaps back into position (E). This will lock down the CPU (F).

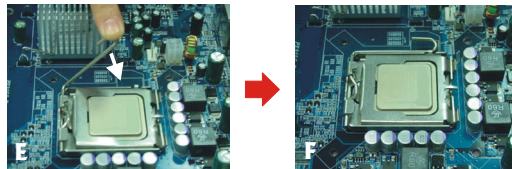

4. Smear thermal grease on the top of the CPU. Lower the CPU fan onto the CPU/CPU socket and secure it using the attachments or screws provided on the fan. Finally, attach the fan power cord to the **CPUFAN** header.

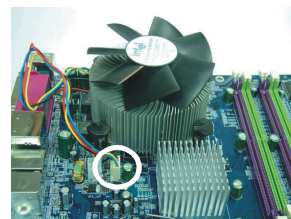

#### Attention

DO NOT touch the CPU pins in case they are damaged. Also, make sure that you have completed all installation steps before powered on the system. Finally, double-check that the cooling fan is properly installed and the CPU fan power cord is securely attached, in case your CPU and other sensitive components are damaged because of high temperatures.

## Mainboard PX915P-2V

### FAN Headers: CPUFAN, AUXFAN, CHASFAN

There are three fan headers available for cooling fans. The cooling fans play an important role in maintaining ambient temperatures in your system. The CPUFAN header is attached with a CPU cooling fan. The CHASFAN and AUXFAN headers are attached with other cooling fans.

 CPUFAN	Pin	Assignment
	1	Ground
2	+12V	
3	FAN RPM rate sense	
4	Control	

 AUXFAN/ CHASFAN	Pin	Assignment
	1	Ground
2	Power (+12V)	
3	FAN RPM rate sense	



#### Attention

You can avoid damaging your CPU due to high temperatures with proper cooling equipment. It is recommended that attach a cooling fan on top of your CPU. Use the CPUFAN header to attach the fan cord. On most fan power cord, the black wire of the fan cable is the "ground" and should be attached to pin-1 of the header.

### Memory Installation: DIMM1/2

The PX915P-2V provides four DIMM (Dual In-Line Memory Modules) sockets which allowing you to install 240-pin, unbuffered non-ECC, DDRII 400/ DDRII 533 SDRAMs. It also supports Dual Channel Technology and allows you installing a total memory capacity of 4 GB.

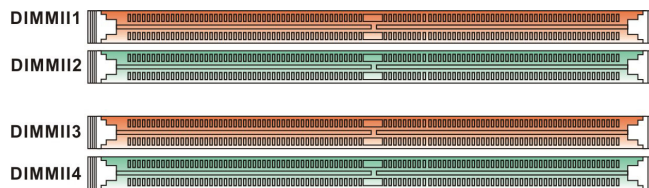

#### Attention

It is recommended that to install memories which are identical specifications (same timing specifications and same DDR speed) to achieve the best effects. It may cause the failure of power-on or lower memory speed if installing different type, SPD (series presence detects) memories.

## **Mainboard PX915P-2V**

### **How to enable Dual-Channel DDRII:**

1. This mainboard provides Dual-Channel functionality for the four DIMM sockets. Enabling Dual-Channel can significantly increase your data access rates. DIMM1 and DIMM2 share one channel, and DIMM3 and DIMM4 share another channel.

For enabling Dual-Channel, you have to install memories in different channel of DIMM sockets; according to the definition by Intel, once one channel of the memory capacity is the same with the other channel, then Dual-Channel will be enabled.

For example: If you install one 256 MB memory in DIMM1 and one in DIMM2 (256MB x 2 = 512MB), you must install a total of 512 MB memory in DIMM3 or DIMM4, so that the Dual-Channel can be enabled.

2. If you only need to install one memory, it is recommended to install it in DIMM1 or DIMM3.

### **Memory Installation Steps:**

1. Pull the white plastic tabs at both ends of the slot away from the slot.

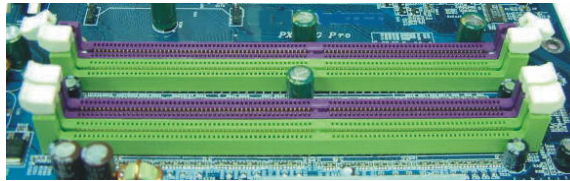

2. Match the notch on the RAM module with the corresponding pattern in the DIMM slot. This will ensure that the module will be inserted with the proper orientation.

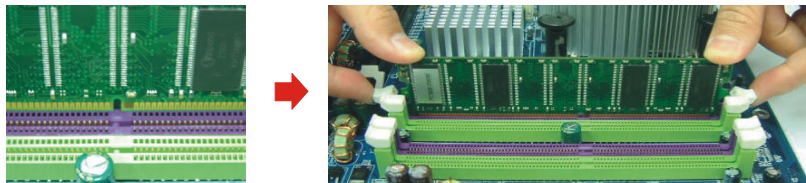

3. Lower the RAM module into the DIMM Slot and press firmly using both thumbs until the module snaps into place.

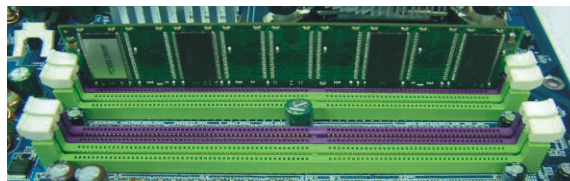

4. Repeat steps 1, 2 & 3 for the remaining RAM modules.

\* The pictures above are for reference only. Your actual installation may vary slightly from the pictures.

## Mainboard PX915P-2V

### Back Panel Configuration

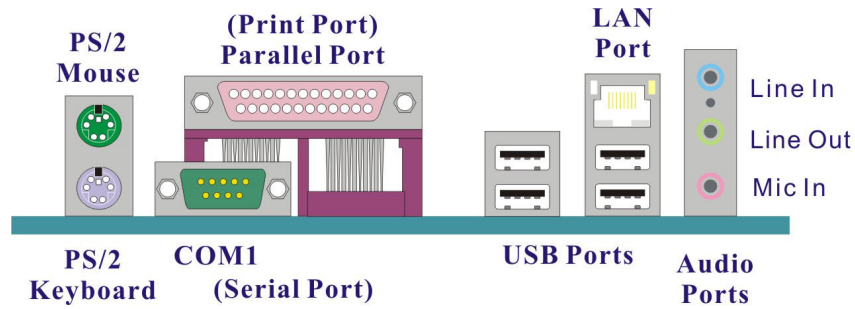

#### PS/2 Mouse & PS/2 Keyboard Ports: KB/MS

This mainboard provides a standard PS/2 mouse port and a PS/2 keyboard port. The pin assignments are described below.

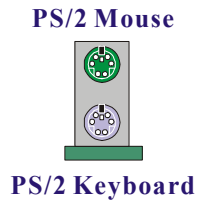

Pin	Assignment	Pin	Assignment
1	Data	4	+5 V (fused)
2	No connect	5	Clock
3	Ground	6	No connect

#### Serial and Parallel Interface Ports

The mainboard provides one serial port and one parallel port on the back panel.

##### Parallel Interface Port: PRT

The parallel port on your mainboard is a standard 25-pin one, and is used to connect with a parallel printer.

##### The Serial Interface: COM

This mainboard provides a serial port COM on your back panel, and is used to connect a mice, modem, or other peripheral device. Through this port, you can also transfer data from your computer hard disk drive to other computers.

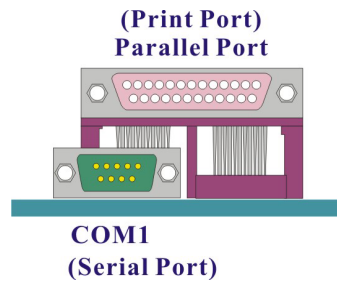

## Mainboard PX915P-2V

### USB Ports/LAN Port: USB/ GBLAN, USB/LAN(GBLAN is optional)

There are four onboard USB 2.0/ 1.1 ports on the back panel. These USB ports are used to attach with USB devices, such as keyboard, mice and other USB supported devices. There is also a 10/100 Mbps Ethernet LAN port (1GbLAN is optional) available for you to attach an Internet cable.

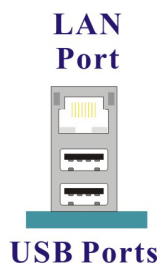

Pin	Assignment	Pin	Assignment
1	TX+ (TX+)	5	NC (TRD2-)
2	TX- (TX-)	6	RX- (RX-)
3	RX+ (RX+)	7	NC (TRD3+)
4	NC (TRD2+)	8	NC (TRD3-)

Pin	Assignment	Pin	Assignment
1/5	+5 V (fused)	3/7	USBP0+/P1+
2/6	USBP0-/P1-	4/8	Ground

### Audio Ports: Sound

This mainboard provides three audio ports, the Mic-in, Line-in and Line-out. These are the standard audio ports that provide basic audio function.

#### Line-In (Blue)

This port is for audio input and connects to external audio devices such as CD player, tape player, etc. When the Super 5.1 Channel Audio Effect is enabled, this port will output audio for the rear speakers.

#### Line-Out (Green)

This port is an output audio port used for connecting to speakers or a headset. When the Super 5.1 Channel Audio Effect is enabled, this port will output audio for the front speakers.

#### Mic-In (Pink)

This port is for connecting to a microphone. When the Super 5.1 Channel Audio Effect is enabled, this port will output audio for your subwoofer/center speakers.

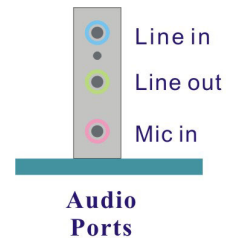

This mainboard supports Super 5.1 Channel Audio Effect which allows you to transform your 2 speaker audio system into a 6 speaker audio system. See **Appendix I** for more information.

## **Mainboard PX915P-2V**

### **Connectors**

#### **Floppy Disk Drive Connector: FDC**

The mainboard provides a standard floppy disk drive connector (FDC) that supports 360KB/720KB/ 1.2MB/1.44MB/2.88 MB floppy disk drives using a FDD ribbon cable.

#### **Primary IDE Connector: IDE1**

The mainboard provides one IDE connectors that support Ultra ATA 66/100/ 133 IDE devices. You can attach a maximum of two IDE devices, such as hard disk drive (HDD), CD-ROM, DVD-ROM, etc. using an IDE ribbon cable.

In general, two IDE devices can be attached onto one IDE connector. If you attach two IDE HDDs, you must configure one drive as the master and the other one as the slave. In this case, one optical device i.e., CD-ROM, DVD-ROM...etc. should be attached to this connector as well.

#### **Serial ATA Connector: SATA1/2/3/4**

The four SATA connectors support 150 Mbps transmission speeds, and one SATA connector only can attach one SATA HDD of each time using SATA cables.

 SATA1~4	Pin	Assignment	Pin	Assignment
	1	Ground	2	RSATA_RXN1~4
	3	RSATA_RXP1~4	4	Ground
	5	RSATA_TXN1~4	6	RSATA_TXP1~4
	7	Ground		



#### **Attention**

The FDD/IDE cable is designed and should be attached with a specific direction. One edge of the cable will usually in color such as red, to indicate that should line up with the header pin-1.

## Mainboard PX915P-2V

### Front Panel Headers: SW/LED、PWRLD、SPEAKER

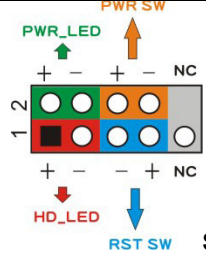

Pin	Assignment	Function	Pin	Assignment	Function
1	HDD LED (+)	Hard Drive LED (HD_LED)	2	Power LED (+)	Power LED (ACPI_LED)
3	HDD LED (-)		4	Power LED (-)	
5	Reset Control (-)	Reset Switch (RST_SW)	6	Power Switch (+)	Power-on Switch (PWR_SW)
7	Reset Control (+)		8	Power Switch (-)	
9	N/C		10	Key	

#### Hard Drive LED Header (Red): HD\_LED

If your case front panel has a hard drive LED cable, attach it to this header. The LED will flicker when there is hard disk drive activity.

#### Reset Switch Header (Blue): RST\_SW

This header can be attached to a momentary SPST switch (reset button) cable on your case front panel. The switch is normally left open. When the switch closed, it will cause the mainboard to reset and run the POST (Power-On Self Test).

#### Power Switch Header (Orange): PWR\_SW

This header can be attached to a power switch cable on your case front panel. You can turn your system on or off by pressing the button attached to this power switch cable.

#### 2-pin Power LED Header (Green): PWR\_LED

The mainboard provides a 2-pin power LED header. If there is a 2-pin power LED cord on your case front panel, you can attach it to the 2-pin power LED header. Then the power LED will illuminate while the system is powered on.

#### 3-pin Power LED Header (Green): PWR\_LED

The mainboard also provides a 3-pin power LED header. If there is a 3-pin power LED cord on your case front panel, you can attach it to this 3-pin header instead of attach to the 2-pin one on the SW/LED header.

 3-pin PWR_LED	<b>Pin</b>	<b>Assignment</b>	<b>Pin</b>	<b>Assignment</b>
	1	PWR_LED (+)	2	Key
	3	PWR_LED (-)		

## **Mainboard PX915P-2V**

### **Speaker Header (Purple): SPEAKER**

A speaker cable on your case front panel can be attached to this header. When you reboot the computer, this speaker will issue a short audible (beep). If there are problems during the Power On Self-Test, the system will issue an irregular pattern of audible beeps through this speaker.

 <b>SPEAKER</b>	Pin	Assignment	Pin	Assignment
	1	PC_BEEP	2	N/C
	3	Ground	4	+5V

## **Headers & Jumpers**

### **Game Port Header: GAME PORT (Optional)**

There is a game port header on this mainboard. To use this header, you must attach a game port bracket-cable (optional) so that you can attach entertainment devices.

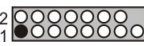
 <b>GAME PORT</b>	Pin	Assignment	Pin	Assignment
	1	+5V	2	+5V
	3	J1B1	4	J2B1
	5	J1CX	6	J2CX
	7	Ground	8	MIDI_OUT
	9	Ground	10	J2CY
	11	J1CY	12	J2B2
	13	J1B2	14	MIDI_IN
	15	+5V	16	Key

### **Case Open Warning Header: CASE OPEN**

This header is used to warn the user when the computer case has been previously opened. To use this function, you have to enable the CASE OPEN warning function in the BIOS Setup Utility. When your computer case is opened, your system will show alert messages during the boot up. (Make sure that your computer case provides this "case open" cable.)

 <b>CASE OPEN</b>	Pin	Assignment	Pin	Assignment
	1	Case open-	2	Ground

## Mainboard PX915P-2V

### Front USB Headers: USB3/USB4

This mainboard provides four onboard USB 1.1/2.0 ports (back panel) that attach to USB devices. There are two additional USB headers that can be connected by cables to four more USB ports on your case front panel giving you a possible 8 USB ports.

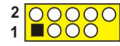
 <b>USB3/USB4</b>	Pin	Assignment	Pin	Assignment
	1	+5V (fused)	2	+5V (fused)
	3	USB-	4	USB-
	5	USB+	6	USB+
	7	Ground	8	Ground
	9	Key	10	Key





#### Attention

If you are using a USB 2.0 device with Windows 2000/XP, you will need to install the USB 2.0 driver from the Microsoft® website. If you are using Service pack 1 (or later) for Windows® XP, and using Service pack 4 (or later) for Windows® 2000, you will not have to install the driver.

### USB Power Selection Headers: JP3/JP4

USB devices attached to the back panel USB ports can awaken the system from sleep mode. In order to enable this functionality, you must adjust the jumper caps on JP3/JP4 header for +5V or +5V Standby mode depending on which port of the compatible device is attached to.



JP3/JP4	Assignment	Description
 <b>Pin 1-2 Closed</b>	+5V	<b>JP3 header:</b> +5V for KB/MS ports and USB/GBLAN ports. <b>JP4 header:</b> +5V for USB/LAN ports.
 <b>Pin 2-3 Closed</b>	+5V Standby	<b>JP3 header:</b> +5V Standby for KB/MS ports and USB/GBLAN ports. <b>JP4 header:</b> +5V Standby for USB/LAN ports.

**Note:** Close stands for putting a jumper cap onto two header pins.

## Mainboard PX915P-2V

### Clear CMOS Jumper: JP1

The "Clear CMOS" function is used when you cannot boot your system due to some CMOS problems, such as a password is forgotten. This jumper allows you to reset the CMOS configurations, and then reconfigure it.

JP1		Assignment
1	 Pin 1-2 Close	Normal (Default)
1	 Pin 2-3 Close	Clear CMOS Data

**Note:** Close stands for putting a jumper cap onto two header pins.



The following steps explain how to reset your CMOS configurations when you have forgotten your system password.

1. Turn off your system and disconnect the AC power cable.
2. Set JP1 header to OFF (2-3 Closed).
3. Wait several seconds.
4. Set JP1 header to ON (1-2 closed).
5. Connect the AC power cable and turn on your system.
6. Reset your new password.

## Audio Configuration

### CD-ROM Audio-In Connector: CD-IN

The CD-IN connector is used to attach an audio cable to audio devices such as CD-ROMs, DVD-ROMs etc.

 CD-IN		Pin	Assignment
		1	Left channel input
		2	Ground
		3	Ground
		4	Right channel input

### SPDIF Header: SPDIF

S/PDIF is a recent audio transfer file format, which provides high quality audio using optical fiber and digital signals. This mainboard is capable to deliver audio output and receive audio input through the SPDIF header. One way you would use this header is by using an SPDIF bracket (optional) and attaching its cord onto this SPDIF header. The RCA or

## **Mainboard PX915P-2V**

TOS-Link connectors will be provided on the bracket and which are convenient you to output or input audio format files between your system and the SPDIF styled devices.

1  SPDIF			
Pin	Assignment	Pin	Assignment
1	+5V	2	Key
3	SPDIF out	4	Ground
5	SPDIF in		

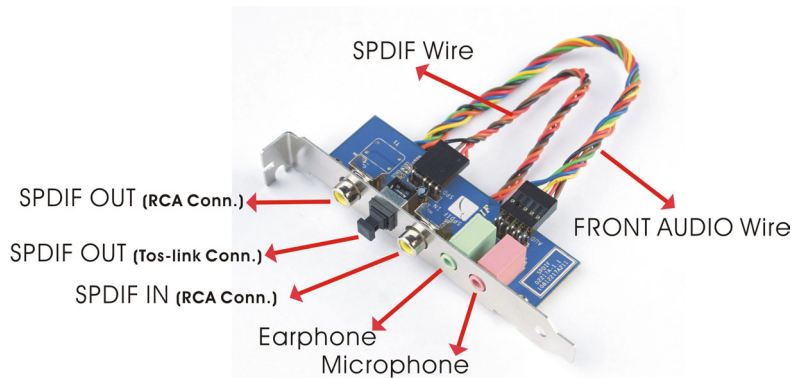

### **Front Audio Header: FRONT AUDIO**

If your case front panel has audio ports, you can connect them to the Front Audio Header of this mainboard. First, you must remove the jumper caps on this header and then attach the cables from the front panel to the pins on this header. You can use both the front audio panel and back panel audio simultaneously. If you are not using front panel audio ports, leave the jumper caps on the header pins (Note: pins 5-6 and 9-10) to avoid problems with the back panel audio ports.

2  FRONT AUDIO			
Pin	Assignment	Pin	Assignment
1	Mic in/center	2	Ground
3	Mic_VREF	4	Audio power +5V
5	Front out_R	6	Rear out_R
7	N/C	8	Key
9	Front out_L	10	Rear out_L

## Mainboard PX915P-2V

### Slots

#### **PCI-Express x16 interface slots: PCI-E X16, PCI-E1**

The PCI-E x16 slot and PCI-E1 slot are the PCI-Express x16 interface slots, which up to x16 and x4 modes can be supported individually. It is recommended that insert a graphics card onto the PCI-E x16 slot, and insert an expansion card which the interface is capable for PCI-E x16 specification onto the other slot, PCI-E1.

#### **PCI Slots: PCI1/PCI2**

PCI stands for Peripheral Component Interconnect and is a bus standard for installing expansion cards such as network card, SCSI card, etc. to these PCI slots.

### Power Supply Attachments

#### **ATX Power Connector: ATX\_PWR、ATX\_12V**

This mainboard provides two ATX power connectors, a 24-pin ATX\_PWR connector and a 4-pin ATX\_12V connector. You must use a power supply that has both of these connectors and both connectors must be attached before the system is powered on. These power connectors support several power management functions such as the instant power-on function. The connector pins are described below.

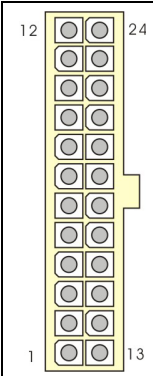
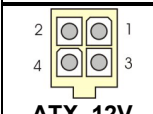
	<b>Pin</b>	<b>Assignment</b>	<b>Pin</b>	<b>Assignment</b>
	1	+3.3V	13	+3.3V
	2	+3.3V	14	-12V
	3	Ground	15	Ground
	4	+5V	16	PS_ON
	5	Ground	17	Ground
	6	+5V	18	Ground
	7	Ground	19	Ground
	8	PW_ON	20	-5V
	9	+5V standby voltage	21	+5V
	10	+12V	22	+5V
	11	+12V	23	+5V
12	+3.3V	24	Ground	
	<b>Pin</b>	<b>Assignment</b>	<b>Pin</b>	<b>Assignment</b>
	1	+12V	3	Ground
2	+12V	4	Ground	



#### **Attention**

In general, power cords are designed and should be attached with a specific direction. The black wire of the power cord is Ground and should be attached onto the header location of Ground.

## **Chapter 2. BIOS Setup**

### **Introduction**

This section describes PHOENIX-AWARD™ BIOS Setup program which resides in the BIOS firmware. The Setup program allows users to modify the basic system configuration. The configuration information is then saved to CMOS RAM where the data is sustained by battery after power-down.

The BIOS provides critical low-level support for standard devices such as disk drives, serial ports and parallel ports. As well, the BIOS controls the first stage of the boot process, loading and executing the operating system.

The PHOENIX-AWARD™ BIOS installed in your computer system's ROM is a custom version of an industry standard BIOS. This means that it supports the BIOS of Intel® based processors.

This version of the PHOENIX-AWARD™ BIOS includes additional features such as virus and password protection as well as special configurations for fine-tuning the system chipset. The defaults for the BIOS values contained in this document may vary slightly with the version installed in your system.

#### **Plug and Play Support**

This PHOENIX-AWARD™ BIOS supports the Plug and Play Version 1.0A specification as well as ESCD (Extended System Configuration Data) write.

#### **EPA Green PC Support**

This PHOENIX-AWARD™ BIOS supports the Version 1.03 of EPA Green PC specification.

#### **APM Support**

This PHOENIX-AWARD™ BIOS supports the Version 1.1 & 1.2 of Advanced Power Management (APM) specification. These features include system sleep and suspend modes in addition to hard disk and monitor sleep modes. Power management features are implemented using the System Management Interrupt (SMI).

#### **PCI/ PCI-Express Bus Support**

This PHOENIX-AWARD™ BIOS also supports Version 2.3 of the Intel PCI (Peripheral Component Interconnect) local bus specification and the PCI-Express v1.0a specification.

#### **DRAM Support**

DDR (Double Data Rate) SDRAM (Synchronous DRAM) is supported.

## **Mainboard PX915P-2V**

### **Supported CPUs**

This PHOENIX-AWARD™ BIOS supports the Intel® Pentium® 4 CPUs.

### **Key Function**

In general, you can use the arrow keys to highlight options, press <Enter> to select, use the <PgUp> and <PgDn> keys to change entries, press <F1> for help and press <Esc> to quit. The following table provides more detail about how to navigate within the BIOS Setup program.

<b>Keystroke</b>	<b>Function</b>
Up arrow	Move to previous option
Down arrow	Move to next option
Left arrow	Move to the option on the left (menu bar)
Right arrow	Move to the option on the right (menu bar)
Esc	Main Menu: Quit without saving changes Submenus: Exit Current page to the next higher level menu
Move Enter	Move to the option you desire
PgUp key	Increase the numeric value or enter changes
PgDn key	Decrease the numeric value or enter changes
+ Key	Increase the numeric value or enter changes
- Key	Decrease the numeric value or enter changes
Esc key	Main Menu – Quit and do not save changes into CMOS Status Page Setup Menu and Option Page Setup Menu – Exit Current page and return to Main Menu
F1 key	General help on Setup navigation keys
F5 key	Load previous values from CMOS
F6 key	Load the defaults from BIOS default table
F7 key	Load the turbo defaults
F10 key	Save all the CMOS changes and exit

## Mainboard PX915P-2V

# Main Menu

When you enter the PHOENIX-AWARD™ BIOS Utility, the Main Menu will appear on the screen. The Main menu allows you to select from several configuration options. Use the left/right arrow keys to select a particular configuration screen from the top menu bar or use the down arrow key to access and configure the information below.

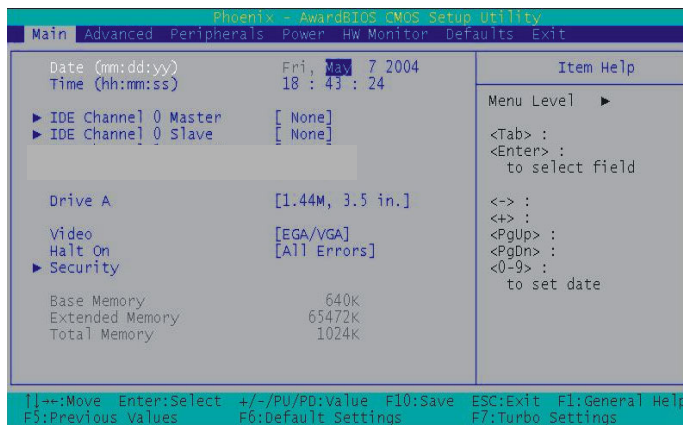

Option	Options	Description
<b>Date</b>	mm dd yyyy	Set the system date. Note that the 'Day' automatically changes when you set the date.
<b>Time</b>	Hh: mm: ss	Set the current time of the system.
<b>IDE Channel 0 Master</b>	Options contained in sub menu.	Press <Enter> to enter the sub menu.
<b>IDE Channel 0 Slave</b>	Options contained in sub menu.	Press <Enter> to enter the sub menu.
<b>Driver A</b>	None; 360K, 5.25 in; 1.2M, 5.25 in; 720K, 3.5 in; 1.44M, 3.5 in; 2.88M, 3.5 in	Select the type of floppy disk drive installed in your system.
<b>Video</b>	EGA/VGA; CGA 40; CGA 80; MONO	Select the default video device.
<b>Halt On</b>	All Errors; No Errors; All, but Keyboard; All, but Diskette; All, but Disk/ Key	Select the situation in which you want the BIOS to stop the POST process and notify you.
<b>Security</b>	Options contained in sub menu.	Press <Enter> to enter the sub menu.
<b>Base Memory</b>	N/A	Displays the amount of conventional memory detected during boot up.
<b>Extended Memory</b>	N/A	Displays the amount of extended memory detected during boot up.
<b>Total Memory</b>	N/A	Displays the total memory available in the system.

# Advanced BIOS Features

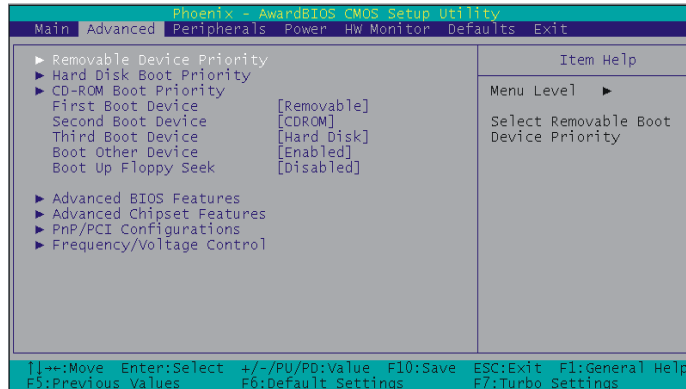

## **Removable Device Priority**

Select removable device boot priority.

## **Hard Disk Boot Priority**

Select hard disk boot priority.

## **First /Second/Third Boot Device**

Select the order in which devices will be searched in order to find a boot device.

Options: Removable (Default for first boot device), Hard Disk (Default for third boot device), CDROM (Default for second boot device), Disabled

## **Boot Other Device**

The setting allows the system to try to boot from other devices if the system fails to boot from the 1st/ 2nd/ 3rd boot devices.

Options: Enabled (Default), Disabled

## **Boot Up Floppy Seek**

When Enabled, the BIOS tests (seeks) floppy drivers to determine whether they have 40 or 80 tracks. Only 360 KB floppy drivers have 40 tracks. Drives with 720 KB, 1.2 MB and 1.44 MB capacity have 80 tracks. Because very few modern PCs have 40-tracks floppy drivers, we recommend that you set this option to "Disabled".

Options: Enabled, Disabled (Default)

## **Mainboard PX915P-2V**

### **Advanced BIOS Features**

#### **CPU Feature**

##### **Delay Prior to Thermal**

Select the delay time before thermal activation from high temperatures.

Options: 4 Min, 8 Min, 16 Min (Default), 32 Min

##### **Thermal Management**

This option will monitor the CPU thermal to prevent the CPU damage with high temperature.

##### **Limit CPUID MaxVal**

When the limit CPUID MaxVal is set to 3, the option should be set to "Disabled" for Windows XP. Options: Enabled, Disabled (Default)

##### **Virus Warning**

This option allows you to choose the Virus Warning feature for IDE Hard Disk boot sector protection. If this function is enabled and someone attempts to write data into this area, BIOS will display a warning message on the screen and sound an audio alarm (beep).

Options: Disabled (Default), Enabled

##### **CPU L1 & L2 Cache**

Make CPU internal cache active or inactive. System performance may degrade if you disable this option. Options: Enabled (Default), Disable.

##### **Hyper-Threading Technology**

When you install a CPU include Hyper-Threading Technology. And this option will allow you to enable or disabled the Hyper-Threading technology.

Options: Disabled, Enabled (Default)

##### **Quick Power On Self Test**

Allow the system to skip certain tests while booting. This will speed up the boot process.

Options: Enabled (Default), Disabled.

##### **Boot Up NumLock Status**

Select the power on state for NumLock.

Options: On (Default)    Numpad keys are number keys.

                  Off                    Numpad keys are arrow keys.

## **Mainboard PX915P-2V**

### **Typematic Rate Setting**

When the options of "Enabled", "typematic rate," and "typematic delay" can be configured, the Typematic Rate determines the keystroke repeat rate used by the keyboard controller.

Options: Disabled (Default), Enabled

### **Typematic Rate (Chars/Sec)**

The rate of a character repeated needs.

Options: 6 (Default), 8, 10, 12, 15, 20, 24, 30

### **Typematic Delay (Msec)**

The delay values before keystrokes begin to repeat.

Options: 250 (Default), 500, 750, 1000.

### **APIC Mode**

"MPS version control for OS" must be configured if this function wants to be enabled.

Options: Disabled, Enabled (Default)

### **MPS Version Control For OS**

The 1.1 version is the older version that supports 8 more IRQs in the Windows NT environment. Choose the new 1.4 version for Windows 2000 and Windows XP.

Options: 1.4 (Default), 1.1

### **OS Select For DRAM > 64MB**

Select "OS2" only if you are running the OS/2 operating system with greater than 64MB of RAM. Options: Non-OS2 (Default), OS2

### **HDD S.M.A.R.T. Capability**

The Self Monitoring Analysis and Reporting Technology is a technology that enables a PC to attempt to predict the possible failure of storage drives.

Options: Disabled (Default), Enabled

### **Intel OSB Logo Show**

This option allows you to show or hide the small LOGO EPA.

Options: Disabled, Enabled (Default)

### **Advanced Chipset Features**

#### **DRAM Timing Selectable**

This option determines DRAM clock/ timing using SPD or manual configuration.

Make sure your memory module has SPD (Serial Presence Data), if you want to select the "By SPD" option.

Options: Manual, By SPD (Default)

#### **CAS Latency Time**

This option determines CAS Latency. When synchronous DRAM is installed, the number of clock cycles of CAS latency depends on the DRAM timing. Do not reset this option from the default value specified by the system engineer. This option is adjustable only when "DRAM Timing Selectable" is set to "Manual". This option is locked when "DRAM Timing Selectable" is set to "By SPD" and is automatically determined by the system.

Options: 5, 4 (Default), 3, Auto

#### **DRAM RAS# to CAS# Delay**

This option allows you to select a delay time between the CAS and RAS strobe signals. It only applies when DRAM is written to, read from, or refreshed. This option is adjustable only when "DRAM Timing Selectable" is set to "manual". This option is locked when "DRAM Timing Selectable" is set to "By SPD" and is automatically determined by the system.

Options: 2, 3, 4 (Default), 5, Auto

#### **DRAM RAS# Precharge**

This option allows you to select the DRAM RAS# precharged time. The ROW address strobe must be precharged again before DRAM is refreshed. An inadequate configuration may result in incomplete data. This option is adjustable only when "DRAM Timing Selectable" is set to "manual". This option is locked when "DRAM Timing Selectable" is set to "By SPD" and is automatically determined by the system.

Options: 2, 3, 4 (Default), 5, Auto

#### **Precharge Delay**

This option allows you to select DRAM Active to Precharge Delay. This option is locked when "DRAM Timing Selectable" is set to "By SPD" and is automatically determined by the system.

Options: 5, 6, 7, 8, 9, 10, 11, 12(Default)

#### **System BIOS Cacheable**

When enabled, accesses to system BIOS ROM addressed at F0000H-FFFFFH are cached, provided that the cache controller is enabled. Options: Enabled (Default), Disabled

## **Mainboard PX915P-2V**

### **Video BIOS Cacheable**

Select "Enabled" to allow caching of the video BIOS which may improve performance. If any other program writes to this memory area, a system error may result.

Options: Enabled, Disabled (Default)

### **Memory Hole at 15M-16M**

When enabled, you can reserve an area of system memory for ISA adapter ROM. When this area is reserved, it cannot be cached. Refer to the user documentation of the peripheral you are installing for more information.

Options: Disabled (Default), Enabled

### **PCI Express Root Port Func**

#### **PCI Express x4 Port 1**

This option allows you to enable or disable PCI Express x 1 port 1.

Options: Auto (Default), Disabled

#### **PCI-E Compliancy Mode**

This option allows you to select the PCI-E Compliancy Mode. Options: V1.0a (Default), V1.0

### **PnP/PCI Configurations**

#### **PCI / VGA Palette Snoop**

Some graphic controllers that are not VGA compatible take the output from a VGA controller and map it to their display as a way to provide boot information and VGA compatibility. Options: Disabled (Default), Enabled

#### **PCI Latency Timer (CLK)**

This option allows you to set up the PCI Latency Time (0-255). If you select the "32" it will optimize PCI speeds.

Options: 0-255 <32 (Default) >

#### **PCI SLOT1/2**

This option allows you to select an IRQ address for PCI slot 1/2. Options: Auto (Default), 3, 4, 5, 7, 9, 10, 11, 12, 14, 15

### **\*\*PCI Express relative Items\*\***

#### **Maximum payload Size**

This option allows you to set the PCI Express Maximum payload size per time.

Options: 4096 (Default), 128, 256, 512, 1024, 2048

### **Frequency/Voltage Control**

#### **Spread Spectrum**

The Spread Spectrum function can reduce the EMI (Electromagnetic Interference) generated. Options: Enabled (Default), Disabled

#### **PCI Speed Setting**

This option determines the PCI frequency (speed settings). You can set the frequency using the supplied BIOS options. One of the options available to you is "Auto". Using the "Auto" option will instruct the system to automatically calculate the frequency.

Options: Auto (Default), 33.0, 37.7, 44.0

#### **PCI-E Speed Setting**

This option determines the PCI-E frequency (speed settings). You can set the frequency using the supplied BIOS options. One of the options available to you is "Auto". Using the "Auto" option will instruct the system to automatically calculate the frequency.

Options: Auto (Default), 100

#### **System Memory Frequency**

This option allows you to select Memory Frequency.

Options: Auto (Default), 400 MHz, 533 MHz

#### **CPU Speed Detected**

This option displays the default CPU speed.

#### **CPU Speed Setting**

This option display the CPU speed that you setting for. If you don't change the "CPU Host Frequency" or the "CPU Clock Ratio" and the option will display the current CPU speed.

#### **CPU Host Frequency (MHz)**

This option displays the CPU Host frequency. You can set it from XXX to 333. The default depends on your CPU frequency. The default for this option depends on the CPU installed.

#### **CPU Clock Ratio**

This option is display only if the CPU has not been set to a locked state by the CPU manufactory. If your CPU is locked, you will not be able to adjust the "CPU Clock Ratio". The default depends on your CPU.

#### **DDR Voltage (Volt)**

This option allows you to adjust the RAM voltage.

Options: Default (Default), +0.05, +0.10, +0.15

#### **NB Voltage (Volt)**

This option allows you to adjust the North Bridge voltage.

Options: Default (Default), +0.05, +0.10, +0.15

## **Mainboard PX915P-2V**

### **Default CPU Voltage (Volt)**

This option displays the CPU default Voltage.

### **CPU Voltage (Volt)**

This option allows you to adjust your CPU core voltage.

Options: Default (Default), +0.05, +0.10, +0.15

## **Peripherals**

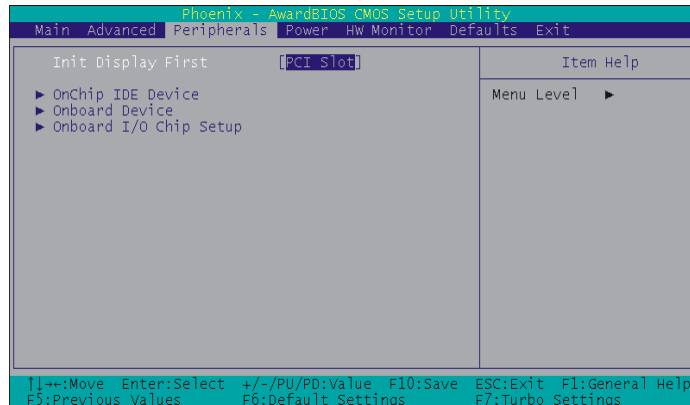

### **Init Display First**

With systems that have multiple video cards, this option determines whether the primary display uses a PCI slot or an AGP slot. Options: PCIEx (Default),PCI Slot

### **OnChip IDE Device**

#### **IDE HDD Block Mode**

Block mode is otherwise known as block transfer, multiple commands, or multiple sector read/write. Select the "Enabled" option if your IDE hard drive supports block mode (most new drives do). The system will automatically determine the optimal number of blocks to read and write per sector. Options: Enabled (Default),Disabled

#### **On-Chip channel0/channel1 PCI IDE**

The mainboard chipset contains a PCI IDE interface with support for two IDE channels. These two IDE channels are for IDE1 and SATA1/2/3/4 connectors use. Select "Enabled" to activate the first and/or second IDE interface. Select "Disabled" to deactivate the interface if you are going to install a primary and/or secondary add-in IDE interface. Options: Enabled (Default),Disabled

#### **IDE channel0/ channel1/Master/Slave PIO**

The IDE PIO (Programmed Input / Output) options let you set a PIO mode (0-4) for each of the IDE devices that the onboard IDE interface supports. Modes 0 to 4 will increase

## **Mainboard PX915P-2V**

performance incrementally. In Auto mode, the system automatically determines the best mode for each device. Options: Auto (Default),Mode0,Mode1,Mode2,Mode3,Mode4.

### **IDE channel0 /channel1 /Master / Slave UDMA**

Ultra DMA 100 functionality can be implemented if it is supported by the IDE hard drives in your system. As well, your operating environment requires a DMA driver (Windows 95 OSR2 or a third party IDE bus master driver). If your hard drive and your system software both support Ultra DMA 100, select "Auto" to enable BIOS support.

Options: Auto (Default),Disabled

### **\*\*\* OnChip Serial ATA Setting\*\*\***

#### **On-chip Serial ATA**

This option allows you to select the on-chip Serial ATA operating mode which will determine how you will use your Serial ATA drives with the other standard IDE drives. This system can physically attach 2 IDE drives and 4 SATA drives but will have certain limitations as described below. Options:

- |               |  |
|---------------|--|
| Disabled      | Disable on-chip serial ATA. No Serial ATA devices installed.   |
| Auto(Default) | BIOS will auto-detect the presence of any SATA devices.<br>2 (or 1) IDE drivers + 4 (or 3) SATA drivers → Enhanced Mode<br>2 (or 1) IDE drivers + 2 (or 1) SATA drivers (Must connect with SATA1 + 3 or with SATA2 + 4) → Combined Mode<br>4 ( or 3 or 2 or 1)SATA drivers → SATA only<br>2 (or 1) IDE drivers → Disabled  |
| Combined Mode | Windows® 98/ME can recognize IDE devices but cannot directly recognize an SATA device and therefore you must use this mode to allow the SATA device to simulate an IDE device by assuming the role of one IDE channel in the system. This means that you will have one available IDE channel for 2 SATA drives to use (each IDE channel can support 2 IDE drives). If you were to install all both IDE drives and 4 SATA drives, you will only see 2 of the SATA drives along with the 2 IDE drives. |
| Enhanced Mode | In this mode, you can use all 6 hard disk drives (including 2 IDE drives and 4 SATA drives).<br><b>Note:</b> You cannot use "Enhanced" mode with Windows® 98/ME. It only supports to install Windows® 2000/ XP if you want to boot from SATA device. (It's restriction from Microsoft.)  |
| SATA Only     | Select this option when you install SATA drives only.  |

#### **PATA IDE Mode**

This option allows you to select an IDE channel for PATA IDE devices. When you install the SATA device(s) to the SATA1 or 3 or 1+3, this option should be set to channel 1. When you install the device(s) to the SATA2 or 4 or 2+4, this option should be set to channel 0.

Options: Channel 0 (Default), channel 1

#### **SATA Port**

This option will display which IDE channel will be used to the SATA device. Options: SATA2, 4 is channel 1

## **Mainboard PX915P-2V**

### **Onboard Device**

#### **USB Controller**

This option should be enabled if your system has a USB port installed on the system board. You will need to disable this feature if you add a higher performance controller.

Options: Enabled (Default), Disabled

#### **USB 2.0 Controller**

This option should be enabled if your system has a USB 2.0 device installed on the system board. You will need to disable this feature if you install a USB 1.1 device.

Options: Enabled (Default), Disabled

#### **USB Keyboard Support**

Enables support for USB attached keyboards. Options: Disabled (Default), Enabled

#### **Audio Device**

This option allows you to control the onboard audio. Options: Auto (Default), Disabled

#### **10/100 Mb LAN Device**

This option allows you to choose whether enable the 10/100 Mb LAN on the mainboard or not. Options: Disabled, Enabled (Default)

### **Onboard I/O Chip Setup**

#### **Power On Function**

This option allows you to select a way to power on your computer.

Options: Password, Hot KEY, Mouse Left, Mouse Right, Any KEY, BUTTON ONLY (Default), and Keyboard 98

#### **KB Power-On Password**

This option is as a part of power-on sequences with your system. This option is configurable only when "Power-On Function" is set with "Password".

#### **Hot Key Power ON**

This option allows you to use the Ctrl key along with a hot key (function key) to power on your system. This option is configurable only when "Power-On Function" is set to "Hot Key".

Options: Ctrl-F1 (Default), Ctrl-F2,..... Ctrl-F12

#### **Onboard FDC Controller**

Select "Enabled" if your system has a floppy disk controller (FDC) installed on the system board and you wish to use it. If you install an add-in FDC or the system has no floppy drive, select "Disabled". Options: Enabled (Default), Disabled

## **Mainboard PX915P-2V**

### **Onboard Serial Port 1**

Select an address and corresponding interrupt for the first/ second serial port.

Options: Disabled,3F8/IRQ4 (Default for port1),2F8/IRQ3,3E8/IRQ4,2E8/IRQ3,Auto

### **UART Mode Select**

This option allows you to select the Infra Red (IR) standard to be used.

Options: Disabled (Default),IrDA

### **RxD, TxD Active**

This option determines the RxD and TxD frequencies. This option is configurable only if "UART Mode Select" is set to "IrDA".

Options: Hi / Lo (Default),Hi / Hi,Lo / Hi,Lo / Lo

### **IR Transmission Delay**

This option allows you to enable/disable IR transmission delay. This option is configurable only if "UART Mode Select" is set to "IrDA".

Options: Enabled (Default),Disabled

### **UR2 Duplex Mode**

Select the transmission mode used by the IR interface. Full-duplex mode permits simultaneous bi-directional transmission. Half-duplex mode permits transmission in only one direction at a time. This option is configurable only if "UART Mode Select" is set to "IrDA". Options: Half (Default),Full

### **Use IR Pins**

Consult your IR peripheral documentation to select the correct setting of the TxD and RxD signals. This option is configurable only if "UART Mode Select" is set to "IrDA".

Options: IR-Rx2Tx2 (Default),RxD2,TxD2

### **Onboard Parallel Port**

Select an address and corresponding interrupt for the onboard parallel port.

Options: 378/IRQ7 (Default),278/IRQ5,3BC/IRQ7,Disabled

### **Parallel Port Mode**

This option allows you to select a parallel port mode for the onboard parallel port.

Options:

ECP (Default)      Extended Capabilities Port.

EPP                  Enhanced Parallel Port.

SPP                  Standard Printer Port.

ECP + EPP          ECP & EPP mode.

Normal

## **Mainboard PX915P-2V**

### **EPP Mode Select**

Select EPP port type 1.7 or 1.9. This option is configurable only if "Parallel Port Mode" is set to "EPP" or "ECP + EPP". Options: EPP 1.9 (Default), EPP 1.7

### **ECP Mode Use DMA**

Select a DMA Channel for the parallel port when using the ECP mode. This option is configurable only if "Parallel Port Mode" is set to "ECP".

Options: 3 (Default), 1

### **PWRON After PWR-Fail**

This option will determine whether your system will boot after restoring power after a power failure. If you select "On", the system will boot whether or not the system was on before power failure. If you select "Former-Sts", the system will be restored to the status before the power failure.

Options: Off (Default), On, Former-Sts

### **Game Port Address**

Game port I/O address. Options: 201 (Default), Disabled, 209

### **Midi Port Address**

Midi port Base I/O address. Options: Enabled (Default), Disabled

### **Midi Port IRQ**

This option determines the IRQ that the Midi Port will use. Options: 10 (Default), 5

## **Power Management**

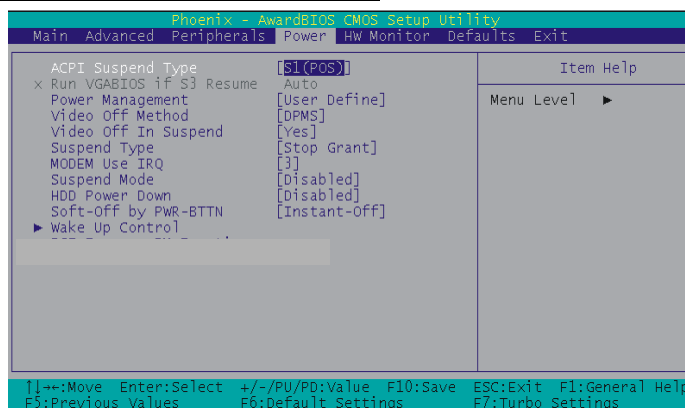

## **Mainboard PX915P-2V**

The Power Management Setup Menu allows you to configure your system to utilize energy conservation features as well as power-up/ power-down options.

### **ACPI Suspend Type**

The option allows you to select the suspend type using the ACPI operating system.

Options:

S1 (POS) (Default)	Power on Suspend
S3 (STR)	Suspend to RAM
S1 & S3	POS and STR

### **Run VGABIOS if S3 Resume**

Select whether you want to run VGABIOS when the system wakes up from the S3 suspend function. This option is not configurable if "ACPI Suspend Type" is set to "S1(POS)".

Options: Auto (Default),Yes,No

### **Power Management**

There are three options of Power Management:

#### 1. Min. Saving

Minimum power management

Suspend Mode = 1hour

HDD Power Down = 15 minutes

#### 2. Max. Saving

Maximum power management (only available for sl CPUs).

Suspend Mode = 1 minute

HDD Power Down = 1 minute

#### 3. User Defined (Default)

This option allows you to set each mode individually.

When this option is enabled, each of the ranges are from 1 minute to 1 hour except for HDD Power Down, which ranges from 1 minute to 15 minute and includes a "disable" option.

**Note:** If you select Min. or Max. Power Saving modes, the "HDD Power Down" value and the "Suspend Mode" value are both fixed.

### **Video Off Method**

This option determines the manner in which the monitor goes blank.

Options:

V/H SYNC + Blank                      This selection will cause the system to turn off the vertical and horizontal synchronization ports and write blanks to the video buffer.

Blank Screen(Default)                This option only writes blanks to the video buffer.

DPMS Support                            Initial display power management signaling.

## **Mainboard PX915P-2V**

### **Video Off In Suspend**

This determines whether power to the monitor is switched off when the computer is in suspend mode.

Options: Yes, No (Default)

### **Suspend Type**

This option allows you to select the suspend type under the ACPI operating system.

Options: Stop Grant (Default), PwrOn Suspend

### **Modem Use IRQ**

This determines the modem's IRQ. Options: 3 (Default), 4, 5, 7, 9, 10, 11, NA.

### **Suspend Mode**

This option allows you to select the suspend time under the ACPI operating system.

Options: Disabled (Default), 1Min, 2Min, 4Min, 8Min, 12Min, 20Min, 30Min, 40Min, 1Hour

### **HDD Power Down**

When enabled, the hard disk drive will power down after a certain configurable period of system inactivity. All other devices remain active.

Options: Disabled (Default), 1 Min, 2 Min, 3 Min, 4 Min, 5 Min, 6 Min, 7 Min, 8 Min, 9 Min, 10 Min, 11 Min, 12 Min, 13 Min, 14 Min, 15Min

### **Soft-Off by PWRBTN**

In situations where the system enters a "hung" state, you can configure the BIOS so that you are required to press the power button for more than 4 seconds before the system enters the Soft-Off state.

Options: Delay 4 Sec, Instant-Off (Default).

### **Wake Up Control**

If you highlight the "Wake Up Control" label and then press the enter key, it will display a submenu with the following options:

#### **PCI PME Wake Up**

This option will also cause the system to wake up with any onboard LAN activity.

Options: Disabled (Default), Enabled

#### **Ring Wake Up**

This option allows you to awaken the system upon receiving an incoming call to modem device. Options: Disabled (Default), Enabled.

## Mainboard PX915P-2V

### **USB KB Wake-up From S3**

This option allows you to awaken the system from suspend mode using a USB keyboard.

Options: Enabled, Disabled (Default)

\* This option is configurable only when the ACPI Suspend Type is set to S3.

### **RTC Wake Up**

When "Enabled", you can set the date and time at which the RTC (real-time clock) alarm awakens the system from Suspend mode. Options: Enabled, Disabled (Default).

### **Date (of Month) Alarm**

You can choose which date of the month the system will boot up. This option is configurable only when "RTC Wake Up" is set to "Enabled".

### **Time (hh: mm: ss) Alarm**

You can choose the hour, minute and second the system will boot up. This option is configurable only when "RTC Wake Up" is set to "Enabled".

### **\*\*Reload Global Timer Events\*\***

When a system goes into suspend mode, certain devices must be inactive for a period of time. Conversely, if any of those devices have any activity, the system will awaken. You can select the devices that will participate in suspend/power-on activity by configuring these options. Devices include: Primary IDE 0/ Primary IDE 1/ Secondary IDE 0/ Secondary IDE 1/ FDD, COM, LPT Port/ PCI PIRQ [A-D]#. Options: Disabled (Default), Enabled

## Hardware Monitor

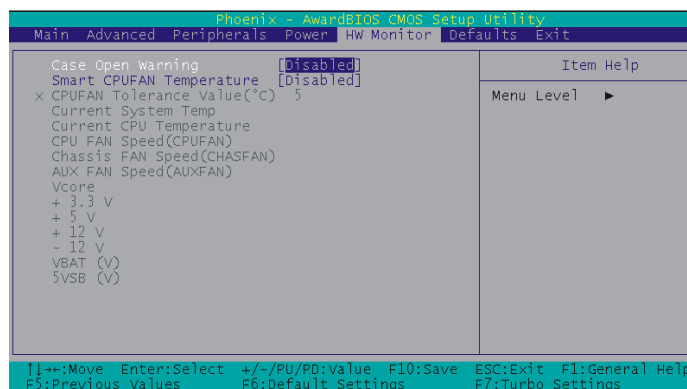

## Mainboard PX915P-2V

### **Case Open Warning**

If this option is set to "Enabled" and the case had been previously opened, the system will automatically display alert messages on the screen when you power on your computer. If this is set to "Disabled", the system will not show alert messages when you power on your computer even if the case had been previously opened.

Options: Disabled (Default),Enabled

### **Smart CPUFAN Temperature**

This option allows you to select the CPU temperature. If the CPU temperature is higher than the value you've selected, the CPUFAN will accelerate till the temperature cools down to the defaulted value you set.

Options: Disabled (default),30°C / 86°F,35°C / 95°F,40°C / 104°F,45°C / 113°F,50°C / 122°F,55°C / 131°F,60°C / 140°F,65°C / 149°F,70°C / 158°F,75°C / 167°F,80°C / 176°F,85°C / 185°F

## Defaults

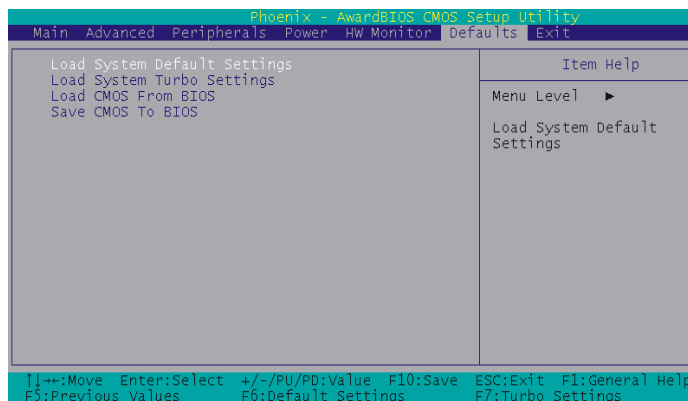

### **Load System Default Settings**

Load System Default Settings.

### **Load System Turbo Settings**

Load System Turbo Settings.

### **Load CMOS From BIOS**

Load defaults from flash ROM for systems without batteries.

### **Save CMOS To BIOS**

Save defaults to flash ROM for systems without batteries.

## Mainboard PX915P-2V

### Exit Menu

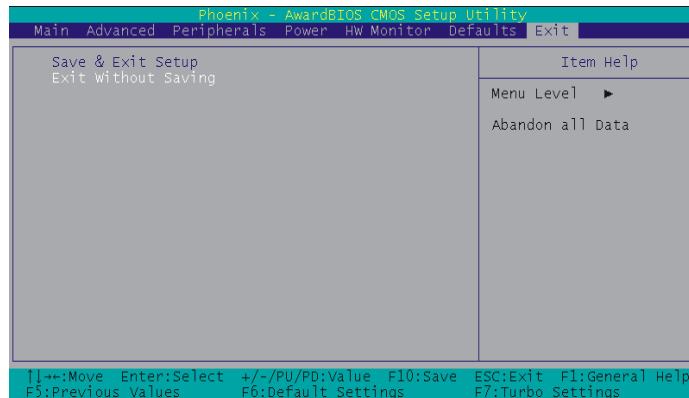

#### **Save & Exit Setup**

Save all configuration changes to CMOS (memory) and exit setup. A confirmation message will be displayed before proceeding.

#### **Exit Without Saving**

Abandon all changes made during the current session and exit setup. A confirmation message will be displayed before proceeding.

## **Chapter 3: Software Setup**

### **Software List**

Category	Platform
Intel Chipset INF	Windows 98 /ME /2000 /XP
Realtek AC' 97 Audio Driver	Windows 2000 /XP
Realtek Network Driver	Windows 98 /ME /2000 /XP
Trend PC-Cillin 2005	Windows 98 /ME /2000 /XP
Microsoft DirectX9.0c	Windows 98 /ME /2000 /XP
Adobe Acrobat Reader 6	Windows 98 /ME /2000 /XP
Dr. Speed	Windows 2000 /XP

**Note:** Due to the Realtek AC'97 Audio Driver and Dr. Speed do not support with Windows® 98/ ME, we strongly recommend you install Windows® 2000/ XP as operating system for this mainboard.

### **Software Installation**

Place the Driver CD into the CD-ROM drive and the Installation Utility will auto-run. You can also launch the Driver CD Installation Utility manually by executing the Intel.exe program located on the Driver CD. (For more details, please refer to the Readme.txt files that in each folder of the Driver.)

© The screen and images are only for general reference. The version of the screens you received with your software may vary slightly.

1. When you insert the driver CD into the CD ROM, you'll see the screen as the picture below. There are several buttons displayed in the main screen as shown below.

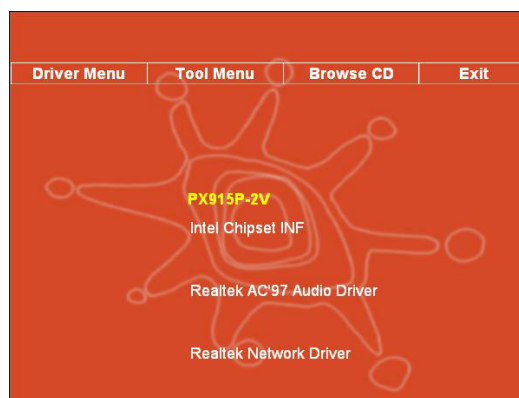

## Mainboard PX915P-2V

- ❖ Intel Chipset INF – It provides all drivers for the functions which built in both the Northbridge/ Southbridge
- ❖ Realtek AC'97 Audio Driver – It provides the driver of Realtek AC'97 Audio Codec

**Note :** You can only install this driver if you are using Windows® XP with Service Pack1 (or more advanced). You will see a screen as shown right after finishing the driver installation and rebooting the system, click "Continue Anyway" to complete the installation. You can only install this driver if you are using Windows® 2000 with Service Pack4 (or more advanced).



- ❖ Realtek Network Driver – It provides the driver of Realtek Network

2. Click the "Utilities" and you can choose the software to install.

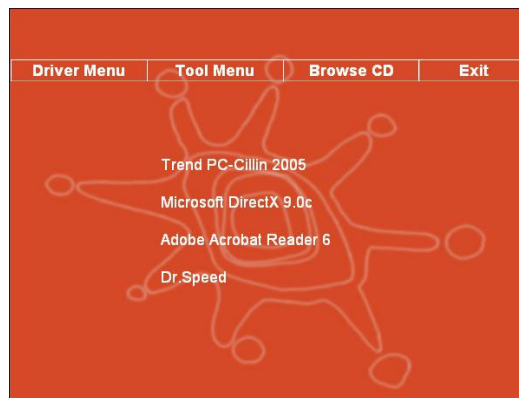

- ❖ Trend PC-Cillin 2005 – It provides the software of Trend PC-Cillin 2005 (Anti-virus program)
- ❖ Microsoft DirectX9.0c – It provides the software of Microsoft DirectX9.0c
- ❖ Adobe Acrobat Reader 6 – Installing the Adobe Acrobat Reader program, you can browse files with pdf styled
- ❖ Dr. Speed – It provides the over-clocking adjustment, hardware monitor, etc. functionalities.

3. If you click the "Browse CD" button from the screen in step 1, you can browse all the files in the Driver CD.

4. Click "Exit" button to exit the program.

## **Chapter 4: Troubleshooting**

### **Problem 1:**

No power to the system. Power light does not illuminate. Fan inside power supply does not turn on. Indicator lights on keyboard are not lit.

Causes:

1. Power cable is unplugged.
2. Defective power cable.
3. Power supply failure.
4. Faulty wall outlet; circuit breaker or fuse blown.

Solutions:

1. Make sure power cable is securely plugged in.
2. Replace cable.
3. Contact technical support.
4. Use different socket, repair outlet, reset circuit breaker or replace fuse.

### **Problem 2:**

System inoperative. Keyboard lights are on, power indicator lights are lit, hard drive is active but system seems "hung"

Causes: Memory DIMM is partially dislodged from the slot on the mainboard.

Solutions:

1. Power Down
2. Using even pressure on both ends of the DIMM, press down firmly until the module snaps into place.

### **Problem 3:**

System does not boot from the hard disk drive but can be booted from the CD-ROM drive.

Causes:

1. Connector between hard drive and system board unplugged.
2. Damaged hard disk or disk controller.
3. Hard disk directory or FAT is corrupted.

Solutions:

1. Check the cable running from the disk to the disk controller board. Make sure both ends are securely attached. Check the drive type in the standard CMOS setup.
2. Contact technical support.
3. Backing up the hard drive is extremely important. Make sure you periodically perform backups to avoid untimely disk crashes.



## **Mainboard PX915P-2V**

### **Problem 4:**

System only boots from the CD-ROM. The hard disk can be read and applications can be used but booting from the hard disk is impossible.

Causes: Hard Disk boot sector has been corrupted.

Solutions: Back up data and applications files. Reformat the hard drive. Re-install applications and data using backup disks.

### **Problem 5:**

Error message reading "SECTOR NOT FOUND" displays and the system does not allow certain data to be accessed.

Causes: There are many reasons for this such as virus intrusion or disk failure.

Solutions: Back up any salvageable data. Then performs low level format, partition, and then a high level format the hard drive. Re-install all saved data when completed.

### **Problem 6:**

Screen message says "Invalid Configuration" or "CMOS Failure."

Causes: Incorrect information entered into the BIOS setup program.

Solutions: Review system's equipment. Reconfigure the system.

### **Problem 7:**

The Screen is blank.

Causes: No power to monitor.

Solutions: Check the power connectors to the monitor and to the system.

### **Problem 8:**

Blank screen.

Causes:

1. Memory problem.
2. Computer virus.

Solutions:

1. Reboot computer. Reinstall memory. Make sure that all memory modules are securely installed.
2. Use anti-virus programs to detect and clean viruses.

### **Problem 9:**

Screen goes blank periodically.

Causes: Screen saver is enabled.

Solutions: Disable screen saver.



## **Mainboard PX915P-2V**

### **Problem 10:**

Keyboard failure.

Causes: Keyboard is disconnected.

Solutions: Reconnect keyboard. Replace keyboard if you continue to experience problems.

### **Problem 11:**

No color on screen.

Causes:

1. Faulty Monitor.
2. CMOS incorrectly set up.

Solutions:

1. If possible, connect monitor to another system. If no color appears, replace monitor.
2. Call technical support.

### **Problem 12:**

The screen displays "C: drive failure."

Causes: Hard drive cable not connected properly.

Solutions: Check hard drive cable.

### **Problem 13:**

Cannot boot the system after installing a second hard drive.

Causes:

1. Master/slave jumpers not set correctly.
2. Hard drives are not compatible / different manufacturers.

Solutions:

1. Set master/slave jumpers correctly.
2. Run SETUP program and select the correct drive types. Call drive manufacturers for possible compatibility problems with other drives.

### **Problem 14:**

Missing operating system on hard drive.

Causes: CMOS setup has been changed.

Solutions: Run setup and select the correct drive type.

### **Problem 15:**

Certain keys do not function.

Causes: Keys jammed or defective.

Solutions: Replace keyboard.



# **Appendix I: Super 5.1 Channel Audio Effect Setup**

## **Channels Setup**

1. After starting your system, click the Sound Effect Manager icon  from the tool bar on the desktop. You can also find the icon by going to Start-> Setting -> Control Panel.
2. Click the Speaker Configuration button. One of the screens will display as shown below.
3. You can choose a 2, 4 or 6 channel (speaker) system.



## **Super 5.1 Channel Audio Effect**

This mainboard comes with an ALC655 Codec which supports high quality 5.1 Channel audio effects. With ALC655, you are able to use standard line-jacks for surround audio output without connecting to any auxiliary external modules. To use this function, you have to install the audio driver in the bonus Pack CD as well as an audio application supporting 5.1 Channel audio effects. See the audio Port Connectors in the Hardware Installation section for a description of the output connectors.

## **Speaker Test**

Make sure the cable is firmly into the connector.

1. Click the audio icon  from the Windows screen.
2. Click Speaker Test button, you can see the screen like the pictures below.
3. Select the speaker which you want to test by clicking on it.

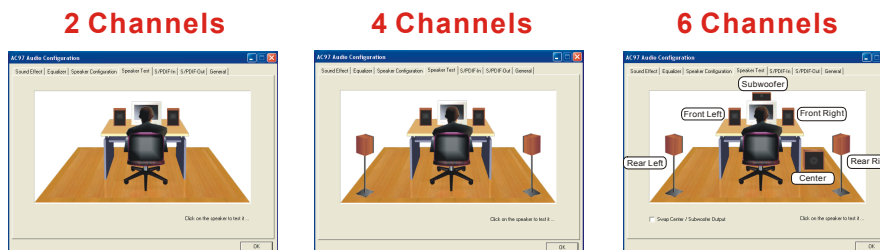

# Appendix II: ABS (Albatron BIOS Security) Card Setup

## Introduction

The ABS (Albatron BIOS Security) system provides your system with a recovery BIOS backup when your onboard BIOS has been damaged beyond system boot capability.

## Preparation and Setup

You should prepare a boot floppy disk and have it ready in case of such BIOS failures. Otherwise you will have to find another computer to make the boot floppy disk from. When you make the disk, you should visit our website and download the latest version of the BIOS file for your mainboard along with the AWDFLASH.exe executable, placing both onto the floppy disk.

## Onboard BIOS Recovery Procedures

1. Make sure your system is turned off.
2. Set the jumper cap on the ABS\_JP1 header located on the ABS Card to the "Rescue BIOS" position (See **Figure 1**).
3. Remove the jumper caps (on pins 1-2, pins 3-4) from the mainboard ABS header (See **Figure 2**).
4. Insert the ABS Card onto the ABS header on the mainboard. The ABS Card will fit over the entire the header and can only be inserted in one direction.

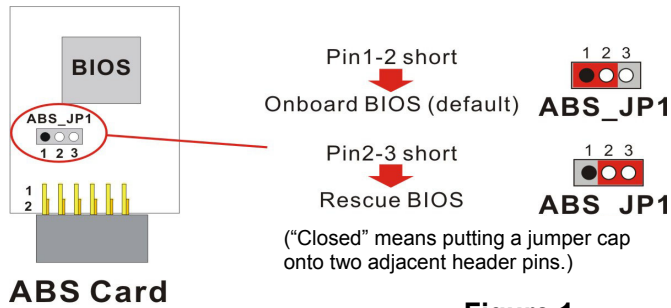

**Figure 1**

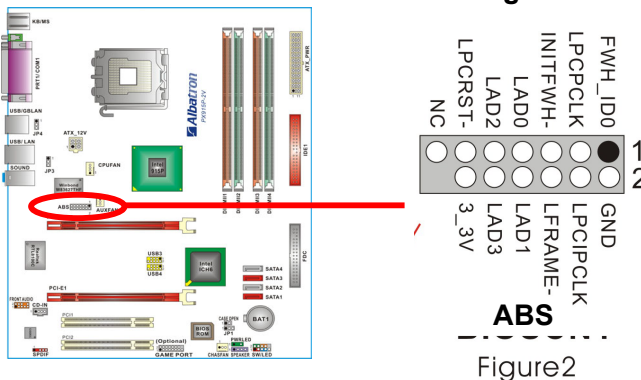

**Figure2**

## Mainboard PX915P-2V

- Place the boot floppy disk (from the "Preparation and Setup" section) into the floppy drive and turn on your system.

**Note:** If your system is not setup to use the floppy drive as the first boot drive, you must enter the BIOS setup utility and make the appropriate adjustments. During the initial boot up sequence the screen will display a message that will give you an opportunity to enter the BIOS setup utility (typically, "Press Delete Key to enter BIOS utility").

Once in the BIOS Utility, follow this path: Advanced -> Hard Disk Boot Priority -> First Boot Device and set the "First Boot Device" to "Removable".

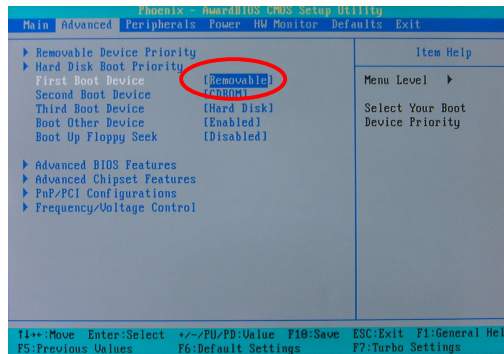

After the system boots from the floppy, the system will enter into the DOS mode (Note that the system has booted using the ABS card's BIOS).

- With the system still running, you must carefully move the jumper cap on the ABS Card (ABS\_JP1 header) back to its "Onboard BIOS" position. This disables the ABS BIOS which will now allow you to flash the corrupted mainboard BIOS from the floppy disk.

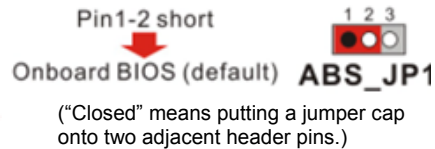

- At the DOS prompt, type "DIR" and take notice of the name of the BIOS file name which ends with the extension ".bin" (e.g. K8N7003.bin). There should also be an AWDFLASH.exe file present. Then type: **awdflash(space)(the file name of .bin).bin** (For example: awdflash(space) k8n7003.bin)

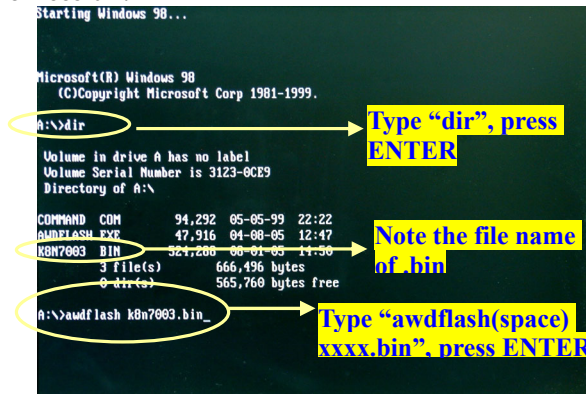

## Mainboard PX915P-2V

8. The initial AWARD BIOS FLASH screen (shown below-left) will appear and prompt you with the message, "Do you want to save BIOS?" Type "**N**" (**Note:** Typing "Y" is only used when saving the BIOS from the onboard BIOS to the floppy disk).

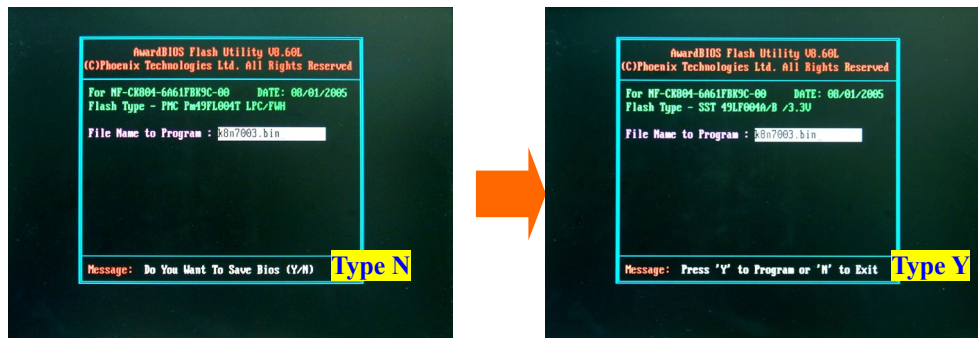

The next screen (shown above-right) will display a message "Press 'Y' to Program or 'N' to Exit". Then type 'Y' to begin the onboard BIOS flash procedure.

9. The flashing procedure will take several minutes and will show its progress on the screen. After the flash BIOS procedures have completed, press '**F1**' to reboot the system.

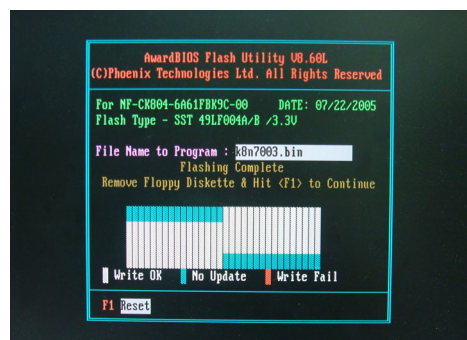

**When the flash process is complete, press 'F1'**



### Attention

While processing the flash BIOS procedures, DO NOT power off or restart your system. Otherwise, it may damage the onboard BIOS.

## Mainboard PX915P-2V

10. During the next boot sequence, enter the BIOS utility program (**Note:** During the boot sequence you will be given a chance to enter the BIOS utility by pressing the "DEL" key on most systems). Load the system with the default settings, and save the changes before exit the BIOS utility program. Then the onboard BIOS recovery procedures are completed at this time.

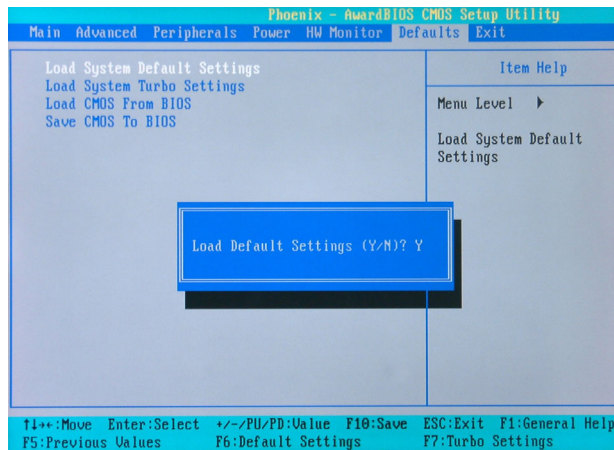

Follow the path: **Defaults -> Load System Default Settings -> Y** .

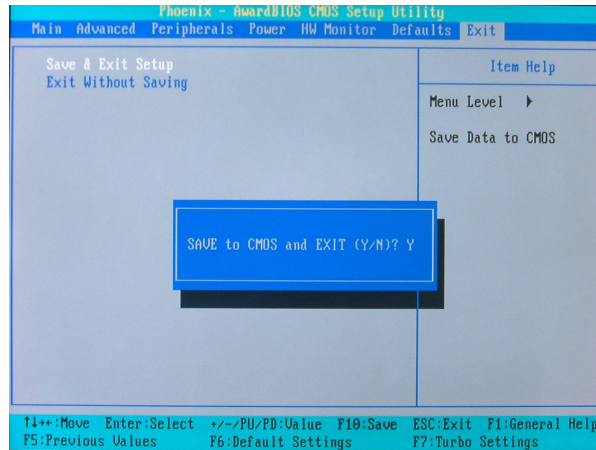

Follow the path: **Exit -> Save & Exit Setup -> Y** .

## Mainboard PX915P-2V

11. After you have recovered your onboard BIOS, you can choose to remove or not remove the ABS Card from the mainboard.

If you do choose to remove the ABS Card from the mainboard, make sure that the system is powered off before you remove the card. After you remove the ABS card you must replace the two jumper caps on the ABS header back to the default positions (pins 1-2 and pins 3-4 are both closed as shown).

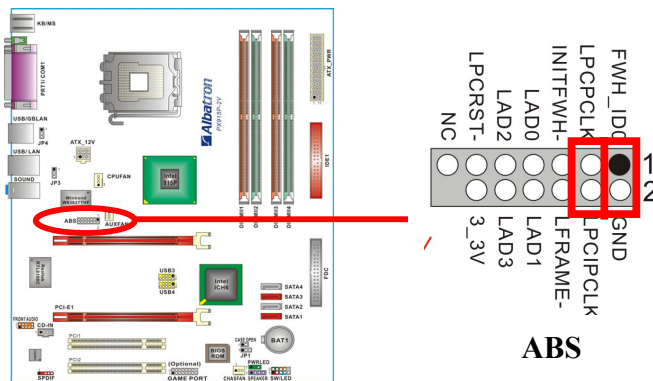

If you choose not to remove the ABS Card from the mainboard, make sure that the jumper caps on the ABS\_JP1 header located on the ABS Card to the "Onboard BIOS" as below, in order to reduce the damage opportunity of the rescue BIOS in ABS Card and on the other hand to extend the usage life of the ABS Card.

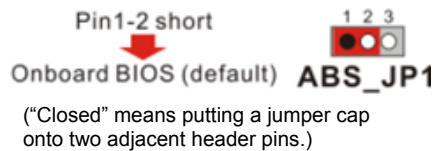

### Attention

If both your onboard BIOS and rescue BIOS are damaged unfortunately, the ABS Card will fail the feature of providing BIOS backup. Therefore, it is recommended that recover the onboard BIOS in advance, and take the ABS Card as emergency happen.