

# PX865PEC PRO(2.0)

## Copyright

All rights are reserved. No part of this publication may be reproduced, transmitted, transcribed, stored in a retrieval system or translated into any language or computer language, in any form or by any means, electronic, mechanical, magnetic, optical, chemical, manual or otherwise, without the prior written permission of the company. Brands and product names are trademarks or registered trademarks of their respective companies.

The vendor makes no representations or warranties with respect to the contents herein and especially disclaim any implied warranties of merchantability or fitness for any purpose. Further the vendor reserves the right to revise this publication and to make changes to the contents herein without obligation to notify any party beforehand. Duplication of this publication, in part or in whole, is not allowed without first obtaining the vendor's approval in writing.

## Disclaimer

We make no warranty of any kind with regard to the content of this user's manual. The content is subject to change without notice and we will not be responsible for any mistakes found in this user's manual. All the brand and product names are trademarks of their respective companies.

## FCC Compliance Statement

This equipment has been tested and found to comply with the limits of a Class B digital device, pursuant to Part 15 of the FCC Rules. These limits are designed to provide reasonable protection against harmful interference in a residential installation. This equipment generates, uses and can radiate radio frequency energy and, if not installed and used in accordance with the instructions, may cause harmful interference to radio communications. Operation of this equipment in a residential area is likely to cause harmful interference in which case the user will be required to correct the interference at his own expense. However, there is no guarantee that interference will not occur in a particular installation.

## Things You have to know !!!

- ⚡ The images and pictures in this manual are for reference only and may vary slightly from actual product installation depending on specific hardware models, third party components and software versions.
- ⚡ Unplug any power connector when installing components and configuring switches and pins on the mainboard.
- ⚡ This mainboard contains very delicate IC chips. Use a grounded wrist strap when working with the system.
- ⚡ Do not touch the IC chips, leads, connectors or other components.
- ⚡ Unplug the AC power when you install or remove any device on the mainboard.

## Packing List

- ◆ PX865PEC PRO(2.0) mainboard
- ◆ FDD Cable
- ◆ HDD Cable
- ◆ Rear I/O panel for ATX case
- ◆ S/PDIF & USB Cables
- ◆ SATA Cable (optional)
- ◆ Mainboard Setup Driver CD
- ◆ Mainboard User Manual CD
- ◆ Mainboard Quick Installation Guide (Optional)

## Symbols

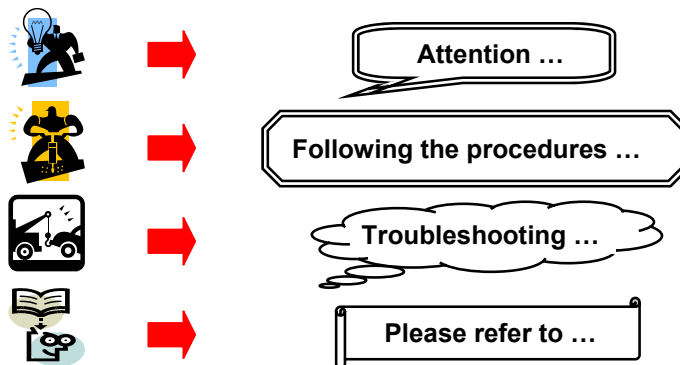

**PX865PEC PRO(2.0)**  
**Intel® 865PE & ICH5**  
**Supports Socket 478 Intel® Pentium® 4 Processor**

# User Manual

**Enabling the Hyper-Threading Technology, your computer system is required as the following components:**

- **CPU:** An Intel® Pentium® 4 Processor with HT Technology
- **Chipset:** An Intel® Chipset that supports HT Technology
- **BIOS:** A BIOS that supports HT Technology and has it enabled
- **OS:** An operating system that supports HT Technology

**For more information on Hyper-Threading Technology, go to:**  
<http://www.intel.com/info/hyperthreading>

**Dimensions (ATX form-factor):**

- 294mm x 225mm (WxL)

**Operating System**

- Windows® XP/ 2000

# Contents

<b>CHAPTER 1. GETTING STARTED .....</b>	<b>1</b>
INTRODUCTION.....	1
SPECIFICATION .....	2
CONFIGURATION .....	5
Layout of PX865PEC PRO(2.0).....	5
HARDWARE INSTALLATION .....	6
CPU Processor Installation .....	6
Memory Installation.....	7
Back Panel Configuration.....	9
Front Panel Headers Indication.....	11
Connectors .....	13
Headers & Jumpers .....	14
Audio Connectors .....	16
Slots .....	17
Power Supply Attachments.....	18
APPENDIX I: SUPER 5.1 CHANNEL AUDIO EFFECT SETUP .....	19

# **Chapter 1. Getting Started**

## **Introduction**

Thanks for choosing the PX865PEC PRO(2.0) mainboard! It is based on the 865PE Northbridge chipset and the ICH5 Southbridge chipset. It supports Intel® Pentium® 4 (Northwood/ Prescott) Processors with FSB (Front Side Bus) 800/533/400 MHz.

The PX865PEC PRO(2.0) mainboard provides 4 sockets using 184-pin DDR SDRAM with a total capacity of up to 4GB. You can install unbuffered & non-ECC DDR400/ 333/ 266 (PC3200/ 2700/ 2100) SDRAM.

The PX865PEC PRO(2.0) mainboard provides one x8 AGP Slot with AGP 3.0 specification and five 32-bit PCI Slots.

The PX865PEC PRO(2.0) mainboard includes two built-in IDE facilities that support Ultra ATA 33/66/100 BMIDE and PIO Modes. It also includes two built-in Serial ATA facilities that support a transfer rate to 150 Mbps.

The PX865PEC PRO(2.0) mainboard comes with an AC'97 Sound Codec (ALC655) which supports high quality 6 channels audio function (Super 5.1 Channel Audio Effect). It also supports Sony/Philips Digital Interface (S/PDIF) function (SPDIF-OUT function is onboard, but SPDIF-IN function is an optional facility).

The PX865PEC PRO(2.0) mainboard also supports to set maximal eight USB 2.0 ports.

Moreover, the PX865PEC PRO(2.0) mainboard comes with a LAN chip which provides the back panel LAN port capable with 10/ 100 Mbps transfer rate.

All of the information in this manual only for reference. This specification is subject to change without notice.

# Specification

## CPU:

- Support Socket 478 Intel® Pentium® 4 processor (Northwood/ Prescott)
- Support Hyper Threading Technology

## Chipset:

- Northbridge Chip (MCH) – Intel® 865PE
- Southbridge Chip (ICH) – Intel® ICH5
- I/O Controller – ITE IT8712F
- AC'97 Audio Codec – ALC655
- LAN Controller – RTL8100C

## DRAM Memory:

- Support DDR400 (PC3200)/ 333 (PC2700)/ 266 (PC2100) SDRAM
- Support 64 MB/128 MB/256 MB/512 MB/1 GB unbuffered & non-ECC DDR memory modules
- Single channel DDR400 memory modules support a bandwidth of 3.2 GB/s
- Dual channel DDR400 memory modules support a bandwidth of 6.4 GB/s
- Support only x8 or x16 DDR devices with four banks
- Support a total memory capacity of 4 GB

## BUS Slots:

- Support one x8 AGP slot (AGP3.0 Specification)
- Support five 32-bit PCI slots

## IDE Facilities:

- Support two IDE Slots
- Support Ultra ATA 33, Ultra ATA 66, and Ultra ATA 100 with BMIDE and PIO modes
- Support high capacity hard drive disks

## Serial ATA Facility:

- Compatible with SATA 1.0
- Support Serial ATA 150MB/sec transfer rate

### **AC'97 Sound Codec Onboard:**

- High performance CODEC with high S/N ratio (>90 dB)
- Compliant with AC'97 2.3 specification
- Support 6-channel playback capability (Super 5.1 Channel Audio Effect)
- Support 3D Stereo enhancement
- Support Sony/ Philips Digital Interface (S/PDIF) function

### **LAN Chip onboard:**

- 10/100 Mbps Ethernet supported

### **I/O facilities:**

- One Multi-parallel Port capable of supporting the following specifications:
  1. Standard & Bi-direction Parallel Port
  2. Enhanced Parallel Port (EPP)
  3. Extended Capabilities Port (ECP)
- Support two serial ports
- Support PS/2 mouse and PS/2 keyboard
- Support 360 KB, 720 KB, 1.2 MB, 1.44 MB, and 2.88 MB floppy drive disks

### **Universal Serial Bus:**

- Support up to eight USB 2.0 ports for USB interface devices

### **BIOS:**

- Phoenix-Award™ BIOS
- Supports APM1.2
- Supports ACPI power management

### **Green Functionality:**

- Support Phoenix-Award BIOS™ power management functionality
- System wake up from power saving sleep mode by touching any keyboard or mouse

### **Hardware Monitor Function:**

- Monitor CPU and all fan speeds
- Monitor CPU temperature and system voltage

## **Watch Dog Timer:**

- This mainboard contains a special feature called the “Watch Dog Timer” which is used to detect when the system is unable to handle over-clocking configurations during the POST stage. Once a problem is detected the system will reset the configurations and reboot the system after five seconds.

# Configuration

## Layout of PX865PEC PRO(2.0)

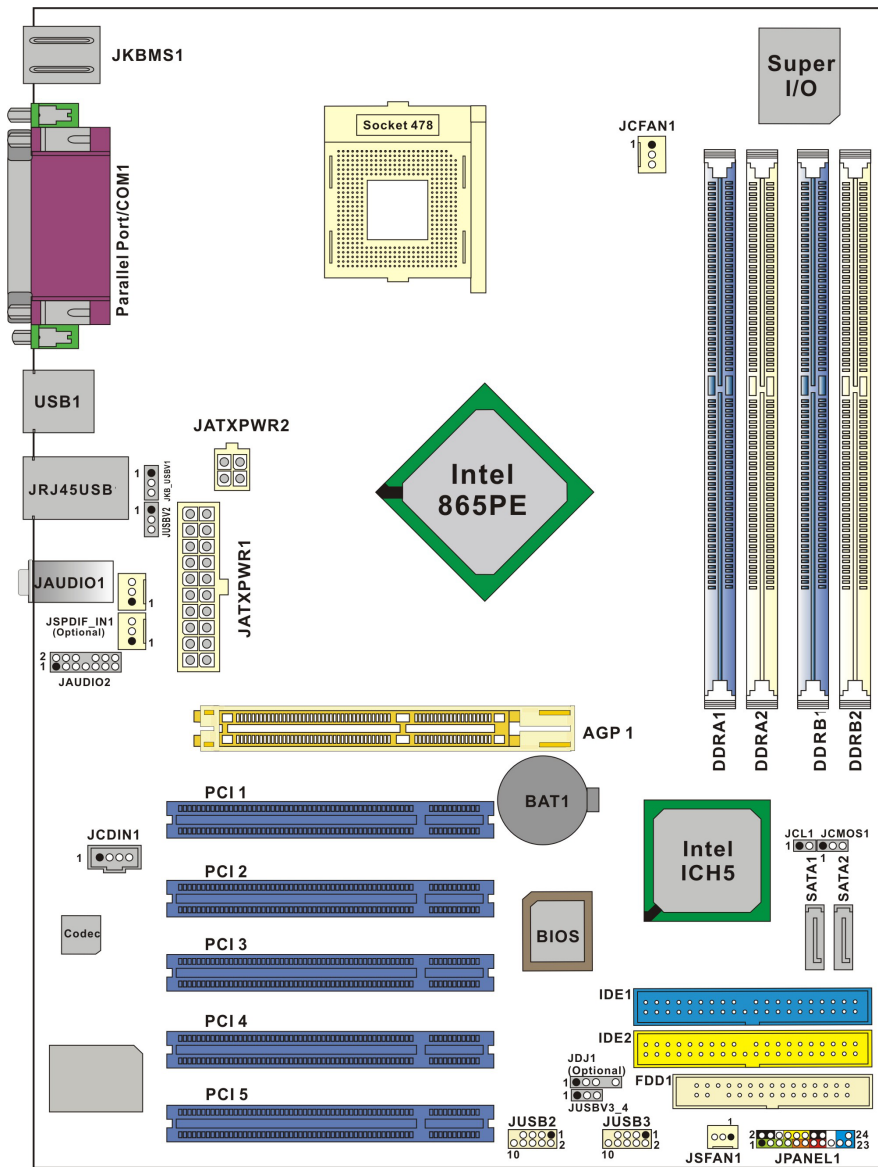

# Hardware Installation

This section will assist you quickly in installing your system hardware. Wear a wrist ground strap before handling components. Electrostatic discharge may damage your system components.

## CPU Processor Installation

This mainboard supports Intel® Pentium® 4 processors using a Socket 478. Before building your system, we suggest you to visit the Intel website and review the processor installation procedures. <http://www.intel.com>

### CPU Socket 478 Configuration Steps:

Locate the CPU socket on your mainboard and nudge the lever away from the socket. Then lift the lever to a 90-degree angle.

On the socket, locate the corner that has the pin-1 receptor. This corner will be near the end of the lever on the socket. Match the dot on the CPU with the pin-1 receptor on the socket and lower the CPU onto the socket. The bottom of the CPU should be flush with the face of the socket.

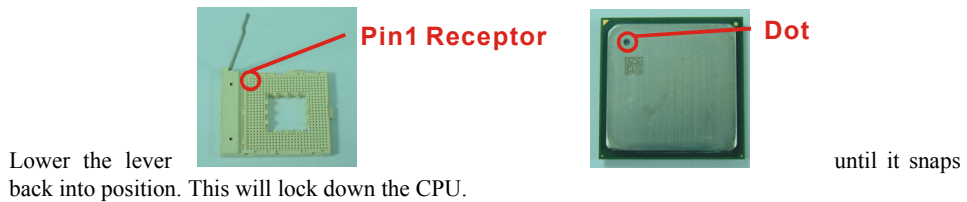

Smear thermal grease on top of the CPU. Lower the CPU fan onto the CPU and use the clasps on the fan to attach it to the socket. Finally, extend the power cable from the fan and insert it onto the JCFANI header.

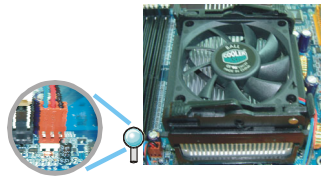

### Attention: Before starting the system

Please check the installation completely before starting the system. Verify that the heatsink is properly installed and make sure the CPU fan is working. Overheating can damage the CPU and other sensitive components.

## FAN Headers: JCFAN1、JSFAN1

Two power headers are available for cooling fans, which play an important role in maintaining the ambient temperature in your system.

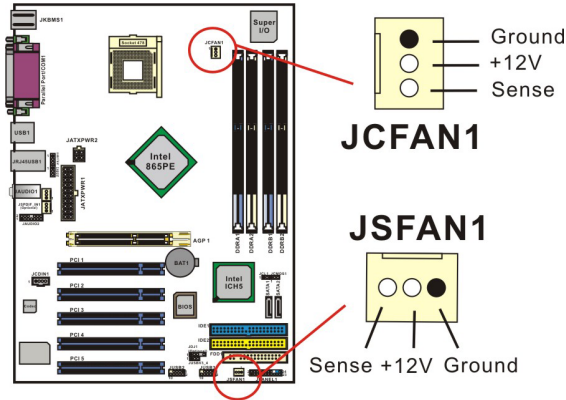

### Attention

We strongly recommend that you use a CPU fan sink with your CPU. You can attach the CPU fan to the JCFAN1 Header.

## Memory Installation

The mainboard contains 4 memory modules which using 184-pin DDR SDRAM with a total memory capacity of up to 4 GB. You can install unbuffered & non-ECC DDR memories. When you installed a 100MHz clock speeds CPU, it can support DDR266. When you installed a 133MHz clock speeds CPU, it can support DDR266/333. And the PX865PEC PRO(2.0) also supports DDR266/320/400 when you installed a 200MHz clock speeds CPU.

The mainboard provides the Dual-Channel function for the memory modules. The DDRA1 and DDRA2 share one channel, while DDRB1 and DDRB2 share the other channel. If you enable these two dual channel functions, it can save time on transferring the data.

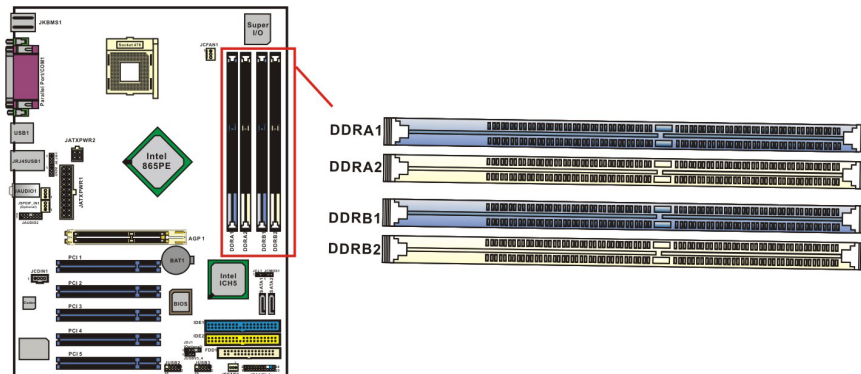

**To Enable Dual-Channel DDR, the following conditions must be met:**

1. You must insert either DDRA1 & DDRA2 together or DDRB1 & DDRB2 together or all four memory modules together.

2. You must insert the same memory configurations between DDRA1 & DDRA2, and DDRB1 & DDRB2.

- Same memory density (128MB, 256MB, 512MB, etc.)
- Same memory technology (128Mb, 256Mb, or 512Mb)
- Same memory bus width (x8 or x16)
- Both either single-sided or dual-sided memory modules
- Same brand memory
- Same clock specifications of memory
- Same memory speeds

A, B => Memory Module Type; X => None.

DDRA1	DDRA2	DDRB1	DDRB2
A	A	A	A
B	B	B	B
A	B	A	B
B	A	B	A
A	X	A	X
B	X	B	X
X	A	X	A
X	B	X	B

**Memory Modules Installation**

The following instructions explain memory module installation for this mainboard:

Before install your memory module, please make sure that the power supply is **UNPLUGGED**. Pull the white plastic tabs at both ends of the slot away from the slot.

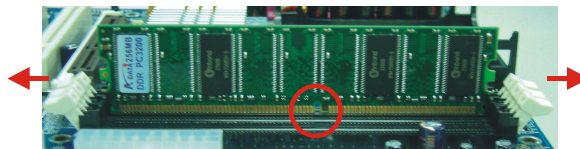

Match the notch on the memory module with the corresponding pattern in the DDR socket. This will ensure that the module will be inserted with the proper orientation.

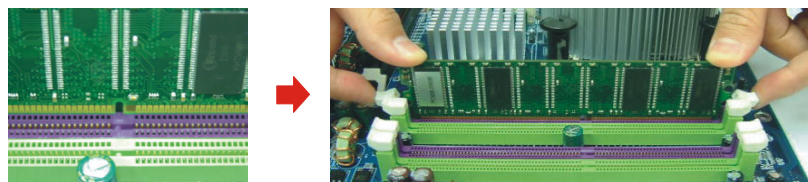

Lower the memory module into the socket and press firmly using both thumbs until the module snaps into place.

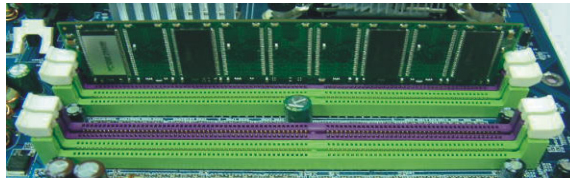

Repeat step 1, 2 & 3 for the remaining memory modules setting.

\* The pictures shown above are for reference only. Your mainboard configuration may vary with the pictures shown.

## Back Panel Configuration

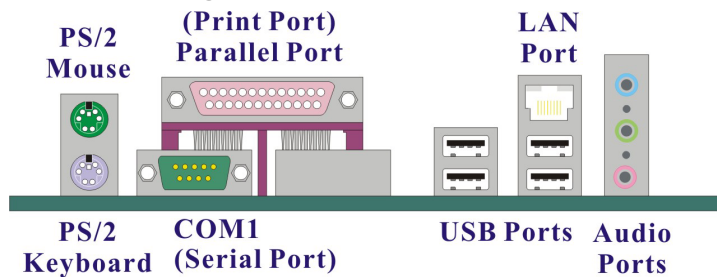

### PS/2 Mouse & Keyboard Connectors: JKBMS1

This mainboard provides a standard PS/2 mouse connector and PS/2 Keyboard connector. The pin assignments are described below:

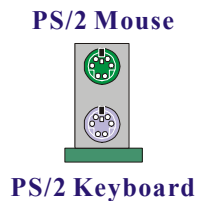

Pin	Assignment	Pin	Assignment
1	Data	4	+5 V (fused)
2	No connect	5	Clock
3	Ground	6	No connect

### Serial and Parallel Interface Ports

The mainboard is equipped with one serial port and one parallel port on the back panel. These interface ports will be explained as below.

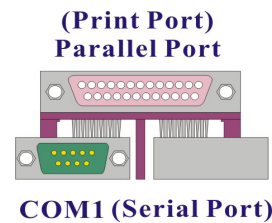

### Parallel Interface Port: JPRNT1

The parallel port on your system has a 25-pin connector and is used to connect parallel printers and other devices which are able to support with this port.

### The Serial Interface: COM1

This mainboard provides a serial port COM1 on the back panel, and is used to connect mice, modems and other peripheral devices. You can also connect your computer to another one through this serial port, in order to transfer data or information from your hard drive disk.

### USB & LAN Ports: JRJ45USB1

There are four USB 2.0/ 1.1 ports on the back panel. These USB ports are used to connect with USB devices, such as keyboard, mice and other USB supported devices. There is also a 10/100 Mbps LAN port available for you to connect a network.

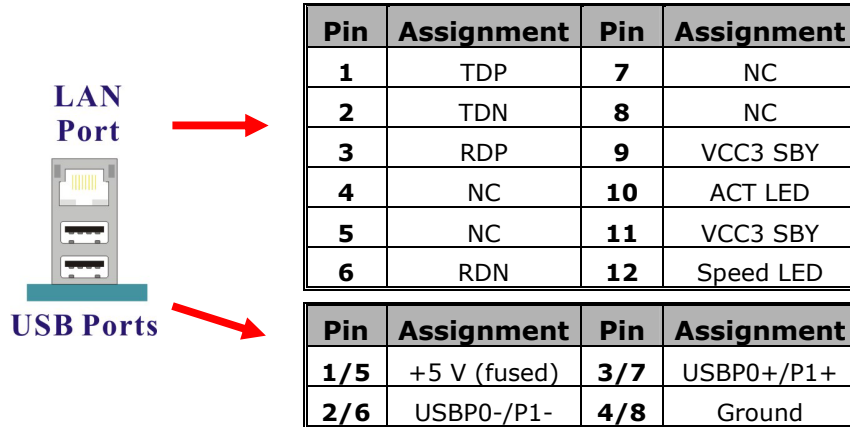

### Audio Port Connectors



**Line In (Blue)** This port is for connecting an external audio device such as a CD player, tape player or other audio devices that provide an audio input. When the Super 5.1 Channel Audio Effect is enabled, your rear speaker function will be enabled with this port.

**Speaker-Out (Green)** It is a standard audio port for connecting the speaker or headphone connectors. When the Super 5.1 Channel Audio driver installed and enabled, your front speaker function will be

enabled with this port. In addition, if you enable the Super 5.1 Channel Audio Effect but using the Standard 2 channel audio function, we suggest you to connect this port, so that the outputted sounds can be high fidelity.

**Mic In (Pink)** This port is for connecting a microphone to input your voice. When the Super 5.1 Channel Audio Effect is enabled, your subwoofer/center function will be enabled.



This mainboard supports Super 5.1 Channel Audio Effect which turns your standard Speaker-Out, Line-In, Mic-In audio connectors into a 6 channel audio system. See Appendix I for

## Front Panel Indicator: JPANEL1

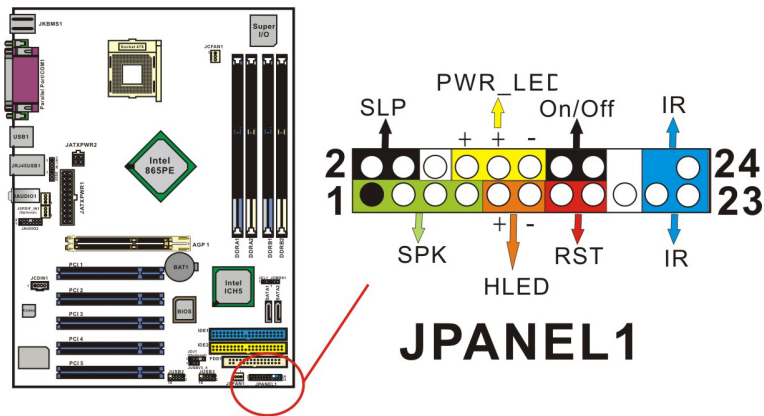

	Assignment	Function	Pin	Assignment	Function
1	+5V	Speaker Connector	2	Sleep control	Sleep button
3	N/A		4	Ground	
5	N/A		6	N/A	N/A
7	Speaker	Hard drive LED	8	Power LED (+)	Power LED
9	HDD LED (+)		10	Power LED (+)	
11	HEE LED (-)		12	Power LED (-)	
13	Ground	Reset button	14	Power button	Power-on button
15	Reset control		16	Ground	
17	N/A	IrDA Connector	18	Key	IrDA Connector
19	N/A		20	Key	
21	+5V		22	Ground	
23	IRTX		24	IRRX	

### **SPK (Speaker Connector)**

A front panel speaker can be connected to this header. When you reboot the computer, the speaker will sound a short “beep”. If there is something wrong during the Power On Self-Test, the speaker otherwise will sound “irregular beep” to warn you.

### **HLED (Hard Drive LED Header)**

This header can be connected to an HLED on the front panel of a computer case. The HLED will flicker during the hard drive disk (HDD) activity. The HDD activity only applies to those IDE devices directly connected to the mainboard.

### **RST (Reset Switch Header)**

This header can be connected to a momentary SPST switch. The switch is normally left open. When the switch closed, it will cause the mainboard to reset and run the POST (Power On Self Test).

### **SLP (Sleep Button)**

Connecting the SLP connector to this header can make the computer system automatically entering into the power saving mode when it is unused.

### **PWRLED (Power LED )**

This mainboard provides a 3-pin power PWRLED header on the front panel of a computer case; connect the 3-pin power LED cable to the header. The PWRLED will illuminate while the computer is powered on.

### **ON/OFF (Power-on Button)**

This header can be connected to a front panel power switch. The switch must pull the Power Button pin to ground for at least 50 ms to signal the power supply to switch on or off (the time required is due to internal debounce circuitry on the system board). At least two seconds must pass before the power supply will recognize another on/off signal.

### **IR (IrDA Connector)**

Connecting the IrDA connector to this header, then you can transfer the data through this function.

## Connectors

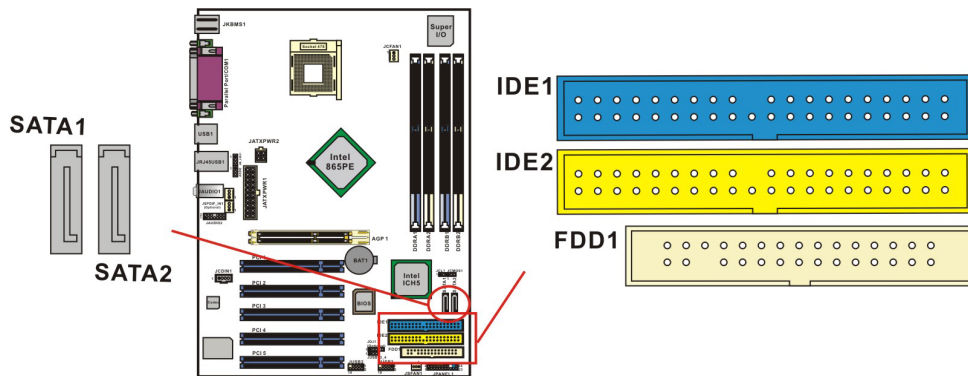

### Floppy Drive Disk Connector: FDD1

The mainboard provides a standard floppy drive connector (FDC) that supports 360K, 720K, 1.2M, 1.44M and 2.88M floppy disks. This connector supports the floppy drive ribbon cables provided in the packaging.

### Hard Drive Disk Connectors: IDE1/ IDE2 、 SATA1/ SATA2

The mainboard has a 32-bit enhanced IDE Controller that supports Ultra ATA 33, Ultra ATA 66, Ultra ATA 100 and Ultra ATA 133. It has two IDE slots, IDE1 and IDE2 for connecting the hard drive disks. You can expand to connect maximal 4 IDE supported devices, such as hard drive disk, CD-ROM, 120MB floppy disk, and so on. The mainboard also has two Serial ATA connectors that support SATA 150 Mbps transfer rate.

### IDE1 (Primary IDE Connector)

You can connect up to two hard drive disks to IDE1. If you attach two HDDs, you must use a ribbon cable with three connectors. You must also configure one drive as the master and one drive as the slave.

### IDE2 (Secondary IDE Connector)

The IDE2 connector can also support a Master and a Slave HDD. The configuration is similar to IDE1.

### SATA1/ SATA2

The SATA connectors support a transfer rate to 150 MB/s. One SATA connector only can connect one serial ATA hard drive disk of each time.

# Headers & Jumpers

## Front USB Headers: JUSB2/ JUSB3

This mainboard provides 4 USB ports and 2 USB headers on the mainboard which allowing you to use 4 additional USB ports. An optional USB bracket may be included with this product. The bracket is typical secured to the back side of your computer case and has standard USB ports that you can connect to external USB devices. The bracket will also have cables that you can extend to the JUSB2 or JUSB3 headers.

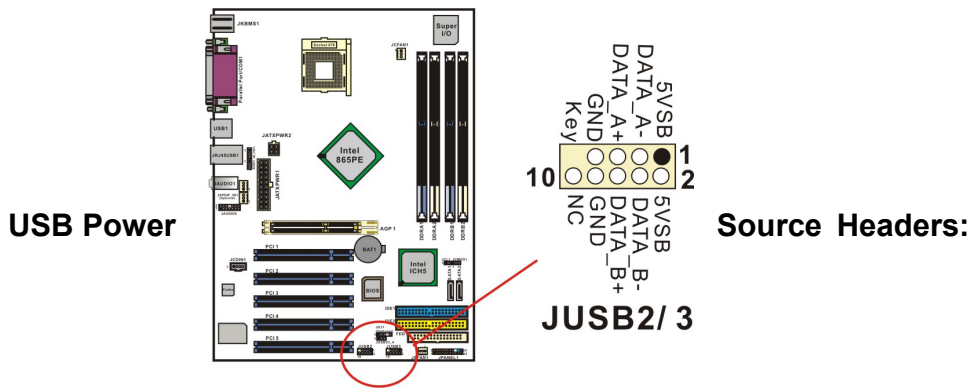

If you are using a USB 2.0 device with Windows® 2000/XP, you will need to install the USB 2.0 driver from the Microsoft® website. If you are using Service pack 1 (or later) for Windows® XP, and using Service pack4 (or later) for Windows® 2000, you will not have to install the driver.

## JKB\_USBV1/2/3\_4

The USB power source headers are included the JKB\_USBV1, JKB\_USBV2, and JKB\_USBV3\_4. These headers will allow you to set your USB power source at +5V. You will need to set to +5V when using a USB hard drive disk.

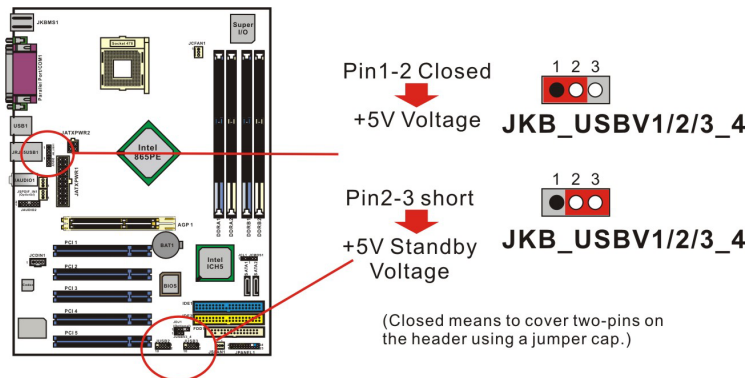

## Clear CMOS Jumper: JCMOS1

The “Clear CMOS” function is used when you cannot boot your system due to some CMOS problems, such as a password is forgotten. This jumper allows you to reset the CMOS configurations, and then reconfigure it.

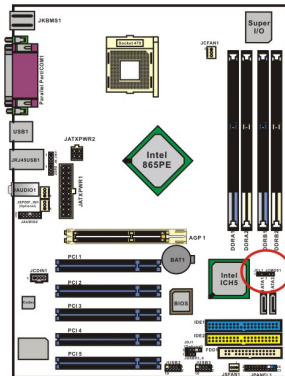

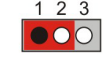
Pin1-2 Closed  
Normal (default)  JCMOS1

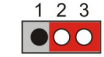
Pin2-3 Closed  
Clear CMOS data  JCMOS1

(Closed means to cover two-pins on a header using a jumper cap.)



The following steps explain how to reset your CMOS configurations when you have forgotten your system password.

1. Turn off your system and disconnect the AC power cable.
2. Set JCOMS1 to OFF (2-3 Closed).
3. Wait several seconds.
4. Set JCOMS1 to ON (1-2 closed).
5. Connect the AC power cable and turn on your system.
6. Reset your new password.

## Audio Connectors

This mainboard provides three connectors as part of its audio Subsystem.

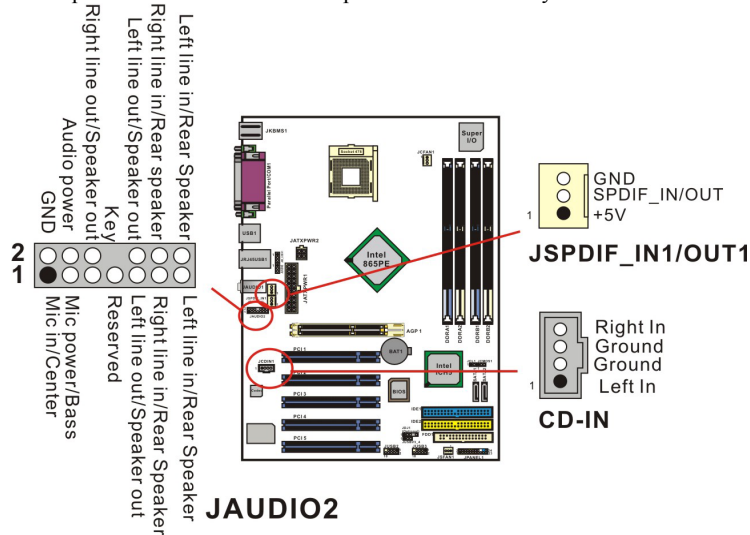

### CD-ROM Audio-In Header: JCDIN1

This header is used to connect to a CD-ROM / DVD audio cable.

### S/PDIF (Sony/Philips Digital Interface) Headers: SPDIF\_IN1/OUT1

S/PDIF is a recent audio transfer file format, which provides high quality audio using optical fiber and digital signals. This mainboard is capable of delivering audio output and receiving audio input through the SPDIF header. One way you would use this header is by using an SPDIF bracket attached to your computer. This bracket will have a cable that you can attach to the SPDIF header. This bracket will also have an RCA connector, similar to that used with most consumer audio products. Using the RCA connector, the data can then be output to and input from an S/PDIF device. The devices that are receiving and sending information from this header must be S/PDIF compliant for optimal effect. Note that the SPDIF output is provided by this mainboard, but SPDIF input is optional in the packaging.

### Front Panel Audio Header: JAUDIO2

If your computer case has the embedded audio equipment design or you are using an audio bracket (optional). You can connect these components to this JAUDIO2 header. First, remove the jumper caps covering the header pins. Connect pin 1 and 3 to the case microphone. Connect pin 9 and 5 to the earphone. If you do not intend to use the front audio panel, do not remove the jumper caps; otherwise, the front panel audio & the back panel audio will disconnect simultaneously.



#### Attention

If the jumper caps are in place, jumper cap 1 is on pin 5 & pin 6, and jumper cap2 is on pin 9 & pin 10.

## Slots

This mainboard provides one AGP slots and five PCI slots. These slots are designed for expansion cards used, in order to complement and enhance the functionality of the mainboard and your system.

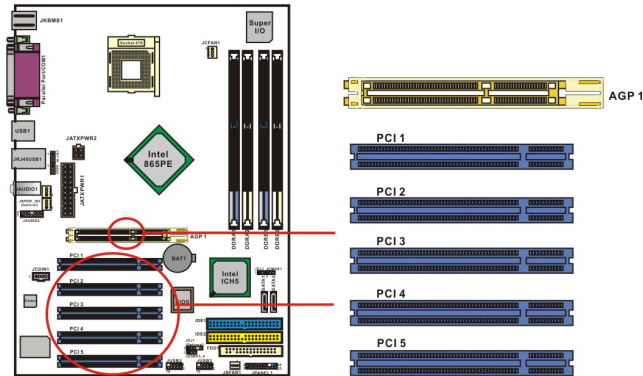

### **AGP (Accelerated Graphics Port) Slot: AGP1**

The mainboard is equipped a x8 Accelerated Graphics Port (AGP) for working with an VGA card.

### **PCI (Peripheral Component Interconnect) Slots: PCI1/2/3/4/5**

This mainboard is equipped with five 32-bit PCI slots. PCI stands for Peripheral Component Interconnect and is a bus standard for expansion cards.

## Power Supply Attachments

### ATX Power Connector: ATX\_PWR、ATX\_PWR2

This mainboard provides two ATX power connectors, one 20-pin connector and one 4-pin connector. Through these connectors to supply the power, the mainboard is able to support several function such as the instant power-on function, and so on. In addition, you have to make sure these connectors are set in secure before applying the power.

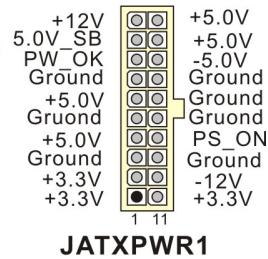
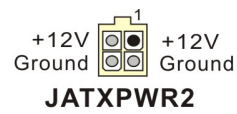
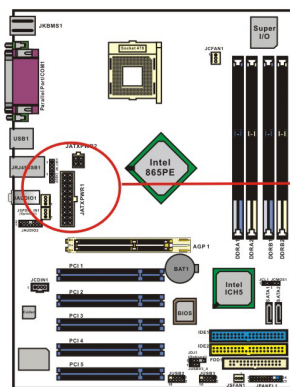

# Appendix I: Super 5.1 Channel Setup

1. After getting into the system, click the audio icon  from the Windows screen.
2. Click Speaker Configuration button, you can see the screen like the picture below.
3. You can choose 2, 4 or 6 channels by your speakers.

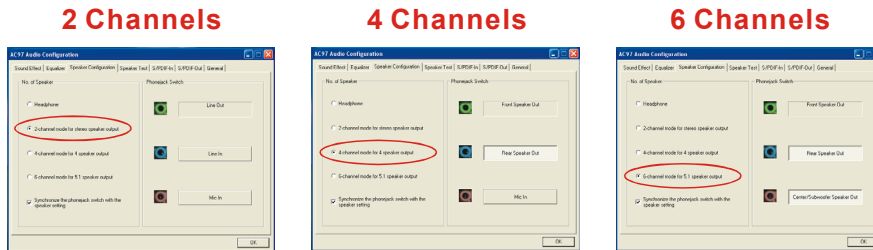

## Super 5.1 Channel Audio Effect

This mainboard comes with an ALC655 Codec which supports high quality 5.1 Channel audio effects. With ALC655, you are able to use standard line-jacks for surround audio output without connecting to any auxiliary external modules. To use this function, you have to install the audio driver in the bonus Pack CD as well as an audio application supporting 5.1 Channel audio effects. See the audio Port Connectors in the Hardware Installation section for a description of the output connectors.

## Speaker Test

Make sure the cable is firmly into the connector.

1. Click the audio icon  from the Windows screen.
2. Click Speaker Test button, you can see the screen like the pictures below.
3. Select the speaker which you want to test by clicking on it.

