

K8M800-754 Series

Copyright

All rights are reserved. No part of this publication may be reproduced, transmitted, transcribed, stored in a retrieval system or translated into any language or computer language, in any form or by any means, electronic, mechanical, magnetic, optical, chemical, manual or otherwise, without the prior written permission of the company. Brands and product names are trademarks or registered trademarks of their respective companies.

The vendor makes no representations or warranties with respect to the contents herein and especially disclaim any implied warranties of merchantability or fitness for any purpose. Further the vendor reserves the right to revise this publication and to make changes to the contents herein without obligation to notify any party beforehand. Duplication of this publication, in part or in whole, is not allowed without first obtaining the vendor's approval in writing.

Trademark

All the trademarks or brands in this document are registered by their respective owner.

Disclaimer

We make no warranty of any kind with regard to the content of this user's manual. The content is subject to change without notice and we will not be responsible for any mistakes found in this user's manual. All the brand and product names are trademarks of their respective companies.

FCC Compliance Statement

This equipment has been tested and found to comply with the limits of a Class B digital device, pursuant to Part 15 of the FCC Rules. These limits are designed to provide reasonable protection against harmful interference in a residential installation. This equipment generates, uses and can radiate radio frequency energy and, if not installed and used in accordance with the instructions, may cause harmful interference to radio communications. Operation of this equipment in a residential area is likely to cause harmful interference in which case the user will be required to correct the interference at his own expense. However, there is no guarantee that interference will not occur in a particular installation.

K8M800-754 Series

VIA® K8M800/ VT8237
Support Socket 754 AMD® Athlon™ 64 Processor

User Manual

Dimensions (ATX form-factor):

- 210mm x 244mm (WxL)

Operating System:

- Supports most popular operating systems: Windows® 2000/XP etc.

Things you have to know !!!

- The images and pictures in this manual are for reference only and may vary with your mainboard configuration which according to different hardware models, third party components and software versions.
- Unplug your computer AC power when installing components and configuring switches and pins.
- This mainboard contains very delicate IC chips. Use a grounded wrist strap when working with the system.
- Do not touch the IC chips, leads, connectors or other components.
- Unplug the AC power when you install or remove any device on the mainboard.

Packing list

- ◆ K8M800-754 mainboard
- ◆ IDE Cable/ FDC Cable
- ◆ USB Bracket (optional)
- ◆ SATA Power cord/ SATA Cable (optional)
- ◆ I/O Shield
- ◆ Mainboard Setup Driver CD
- ◆ Mainboard User Manual CD
- ◆ Mainboard Quick Installation Guide (optional)

Symbols

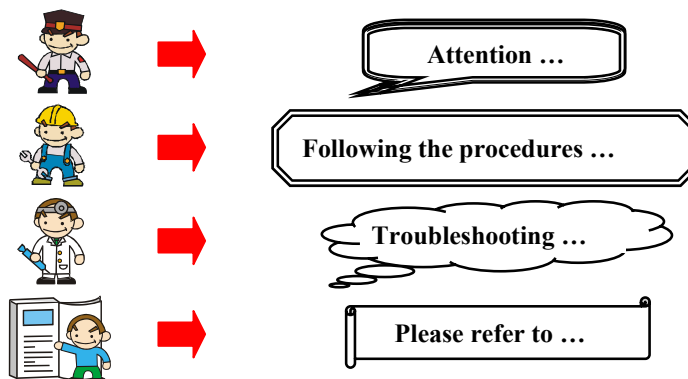

Table of Contents

CHAPTER 1. GETTING STARTED	1
INTRODUCTION	1
SPECIFICATION	2
CONFIGURATION	5
Layout of K8M800-754	5
HARDWARE INSTALLATION.....	6
CPU Processor Installation	6
Memory Installation.....	7
Back Panel Configuration.....	9
Front Panel Headers Indication: SW/LED、PWRLD、SPEAKER.....	11
Connectors	12
Jumpers & Headers.....	13
Audio Connectors	15
Slots	16
Power Supply Attachments.....	17
APPENDIX I: SUPER 5.1 CHANNEL AUDIO EFFECTS SETUP	18
APPENDIX II: SATA RAID 0/1 SPECIFICATION	19

Chapter 1. Getting Started

Introduction

Thanks for choosing the K8M800-754 mainboard! It is based on VIA® K8M800 Northbridge and VIA® VT8237 Southbridge chipset. It also supports AMD® Athlon™ 64 Processor.

The K8M800-754 mainboard provides 2 sockets using 184-pin DDR SDRAM. You can install DDR400/ 333/ 266 (PC3200/ 2700/ 2100) SDRAM, and it supports a total capacity of up to 2GB.

The K8M800-754 mainboard provides one 4X/ 8X (AGP2.0/3.0) AGP Slot and three 32-bit PCI Slots with PCI 2.3 specification.

The K8M800-754 mainboard includes two built-in IDE facilities that support Ultra ATA 33/ 66/ 100/ 133. It also includes two built-in Serial ATA facilities that support SATA RAID 0 or 1 and transfer rate up to 150 MB/sec per channel.

Moreover, the K8M800-754 mainboard has On-board Video Graphic function which is able to support 3D and video acceleration. With Ultra-AGP II™ Technology supported, the video performing efficiency can achieve up to 2 GB/sec of an AGP VGA card worked.

The K8M800-754 mainboard comes with an AC'97 audio controller which supports high quality 6-channel audio function (Super 5.1 Channel Audio Effects).

The K8M800-754 mainboard can support maximal eight USB 2.0 ports.

The K8M800-754 mainboard also comes with a LAN Chip (RealTek RT8100C) which supports a back panel LAN port capable of 10/100 Mbps transfer rate.

All of the information in this manual only for reference. This specification is subject to change without notice.

Specification

CPU

- Support Socket 754
- Support AMD® Athlon™ 64 processor
- HyperTransport™ Link
 - supports 16-bit to be capable of operating up to 800 MHz (1600 MT/sec) with a bandwidth of up to 1.6 Gbytes/sec in each direction

Chipsets

- Northbridge – VIA® K8M800
- Southbridge – VIA® VT8237
- I/O Controller – Fintek® F71805F LPC
- AC'97 Codec – Realtek® ALC655
- LAN Controller – RealTek® RTL8100C

DRAM Memory

- Support DDR400 (PC3200)/ DDR333 (PC2700)/ DDR266 (PC2100) SDRAM
- Support 64 MB/ 128 MB/ 256 MB/ 512 MB/ 1 GB unbuffered with (or without) ECC DIMM modules
- Support up to two memory modules with a total capacity of 2 GB

PCI BUS Slots

- Provide three PCI slots
- Include 33MHz, 32-bit PCI interface, PCI 2.3 is compliant

AC'97 Sound Codec On-board

- High performance CODEC with high S/N ratio (>90 dB)
- Compliant with AC'97 2.3
- Support 6-channel playback capability (Super 5.1 Channel Audio Effects)
- Support 3D Stereo enhancement

LAN Chip

- 10/ 100 Mbps Ethernet supported

IDE Facilities

- Support two IDE PCI interface slots
- Support Ultra ATA 33, Ultra ATA 66, Ultra ATA 100, and Ultra ATA 133 with DMA and PIO mode
- Support high capacity hard drive disks

Universal Serial Bus

- Support up to eight USB 1.1/ 2.0 ports for USB interface devices

On-board Video Graphic Function

- Support 3D Acceleration
- Support Ultra-AGP II™ Technology, the video performing efficiency can achieve up to 2 GB/sec of an AGP VGA card worked
- Support Video Acceleration

Serial ATA Facilities

- Compatible with SATA 1.0
- Support Serial ATA 150 MB/sec transfers rate
- Support SATA RAID 0 or RAID 1 mode

Green Functionality

- Support Phoenix-Award BIOS™ power management function
- Contain an inactivity power down timer that can be set from 1 to 15 minutes
- System wake up from power saving sleep mode by touching any keyboard or mouse

I/O facilities:

- One Multi-parallel Port capable of supporting the following specifications:
 1. Standard & Bi-direction Parallel Port
 2. Enhanced Parallel Port (EPP)
 3. Extended Capabilities Port (ECP)
- Support one Serial Port
- Support PS/2 mouse and PS/2 keyboard
- Support 360 KB, 720 KB, 1.2 MB, 1.44 MB, and 2.88 MB floppy drive disks

BIOS:

- Support Phoenix-Award™ BIOS
- Support APM1.2
- Support ACPI power management

K8M800-754

Hardware Monitor Function:

- Monitors CPU/Chassis Fan Speed
- Monitors CPU & system Temperature
- Monitors System Voltage

Configuration Layout of K8M800-754

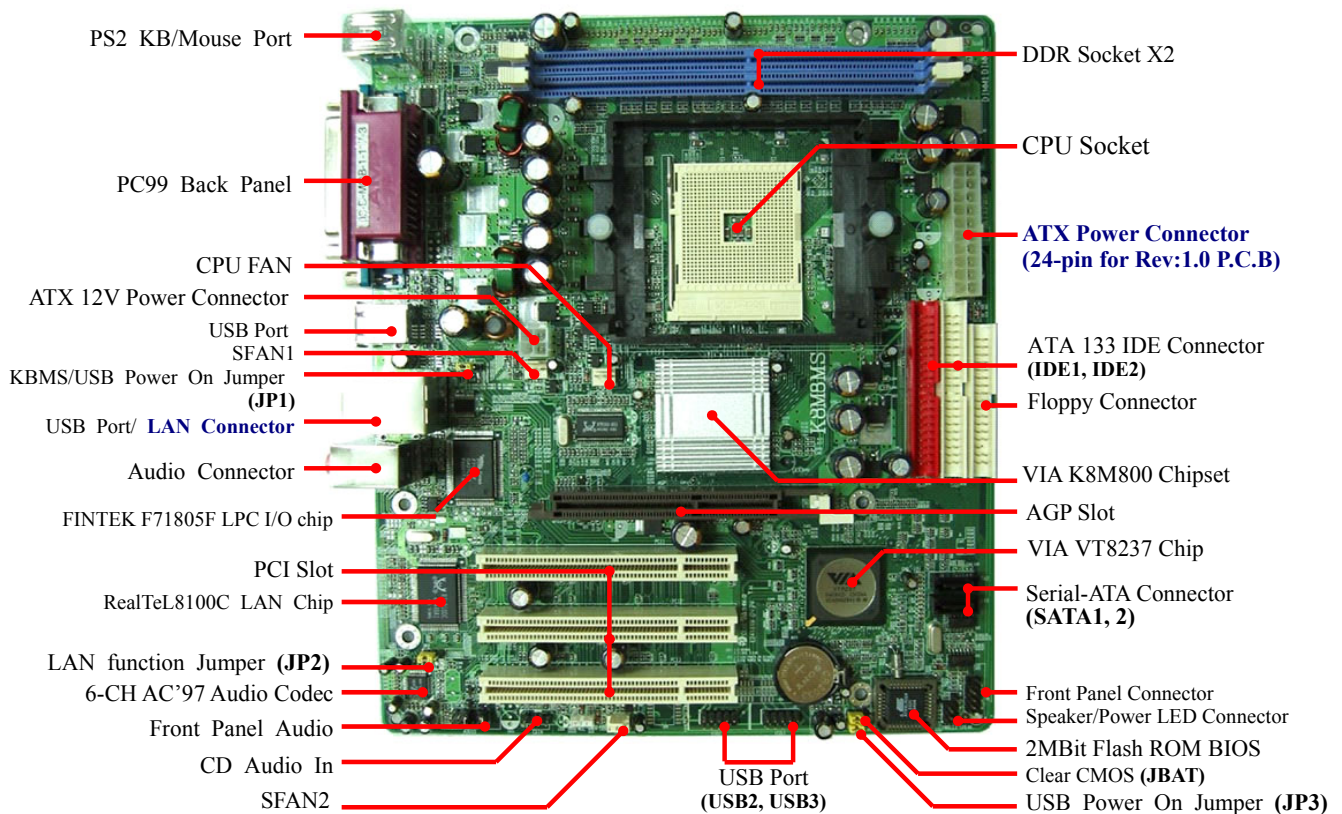

Hardware Installation

This section will assist you quickly in installing your system hardware. Wear a wrist ground strap before handling components. Electrostatic discharge may damage your system components.

CPU Processor Installation

This mainboard supports AMD® Athlon™ 64 processor using a Socket 754. Before building your system, we suggest you to visit the AMD website and review the processor installation procedures. (<http://www.amd.com>)

CPU Socket 754 Configuration Steps:

Locate the CPU socket on your mainboard and nudge the locking lever away from the socket. Then lift the lever to a 90-degree angle.

On the socket, locate the corner which has the “diagonally cut-corner” on the rectangular shaped pattern of pinholes (see diagram below-left). Match that corner with the “gold triangle” on the CPU (see diagram below-right) and lower the CPU onto the socket. The bottom of the CPU should be flush with the face of the socket.

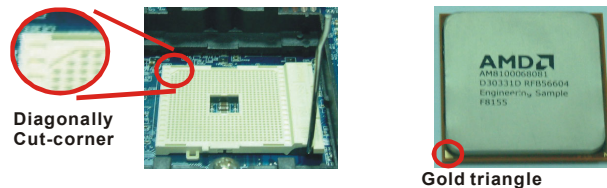

Lower the lever until it snaps back into position. This will lock down the CPU.

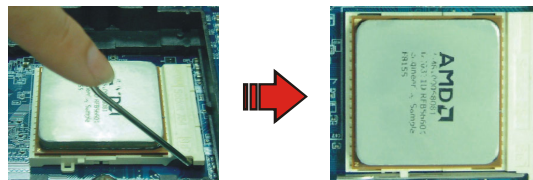

Smear thermal grease on top of the CPU. Lower the CPU fan onto the CPU and use the clasps on the fan to attach it to the socket. Finally, extend the power cable from the fan and insert it onto the “CPUFAN” adapter.

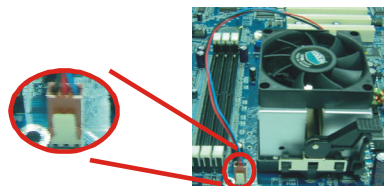

Attention

Overheating may damage the CPU and other sensitive components. Please check the installation completely before starting the system. Make sure the heatsink and the CPU fan are properly installed.

FAN Headers

Three power headers are available for cooling fans, which play an important role in maintaining the ambient temperature in your system.

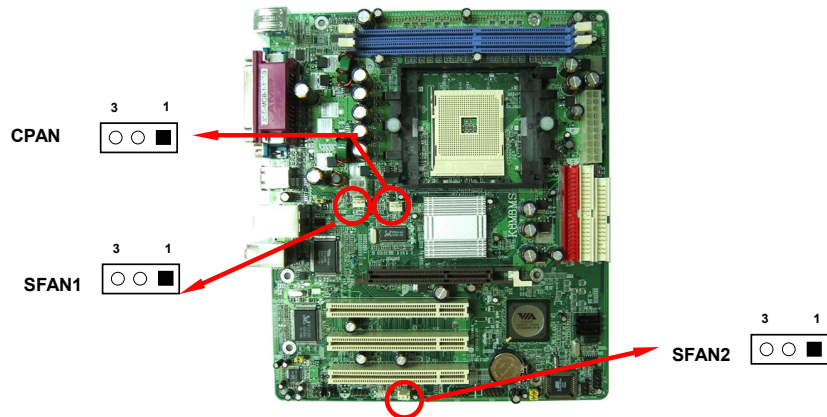

Attention

We strongly recommend that you use a CPU fan sink with your CPU. You can attach the CPU fan to the CPUFAN header.

Memory Installation

The K8M800-754 mainboard contains 2 memory sockets (DIMM), which using 184-pin DDR SDRAM with a total memory capacity of up to 2 GB. You can install unbuffered with (or without) ECC DDR 400/ 333/ 266 (PC3200/ 2700/ 2100) SDRAM on the DIMMs.

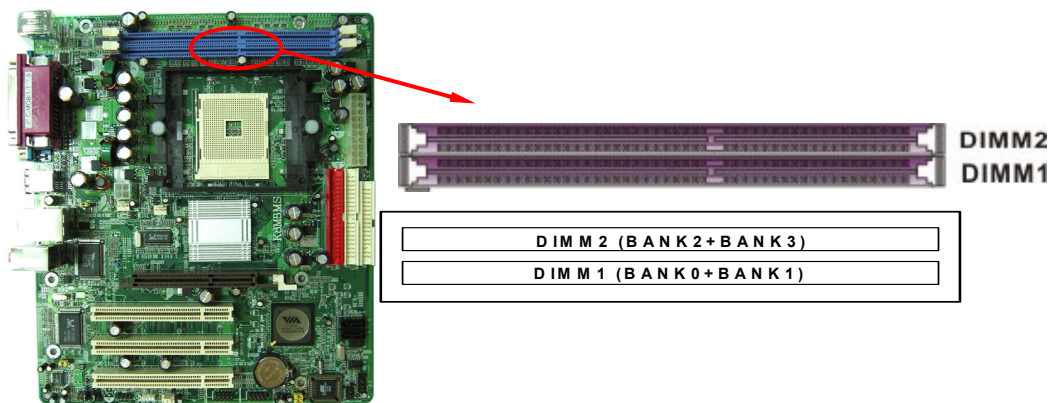

Please refer the table below to setup the memory:

Bank	184-pin DDR DIMM	PCS	Total Memory
Bank 0, 1 (DIMM1)	DDR266/DDR333/DDR400 DDR SDRAM Module	X1	64MB~1.0GB
Bank 2, 3 (DIMM2)	DDR266/DDR333/DDR400 DDR SDRAM Module	X1	64MB~1.0GB
Total	System Memory (Max. 2.0GB)	X2	64MB~2.0GB

Memory Module Installation

The following instructions explain memory module installation for this mainboard:

1. Before install your memory module, please make sure that the power supply is **UNPLUGGED**. Pull the white plastic tabs at both ends of the slot away from the slot.

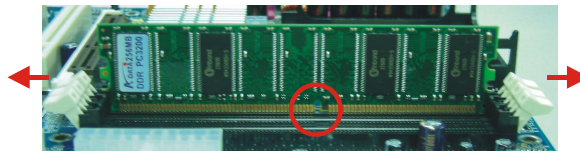

2. Match the notch on the memory module with the corresponding pattern in the DIMM slot. This will ensure that the module will be inserted with the proper orientation.

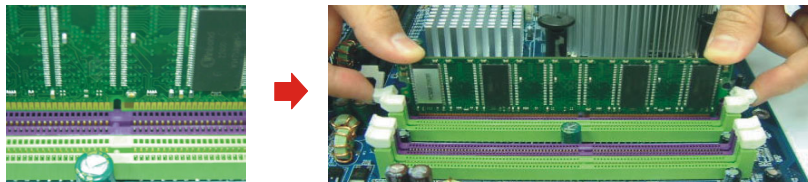

3. Lower the memory module into the DIMM socket and press firmly using both thumbs until the module snaps into place.

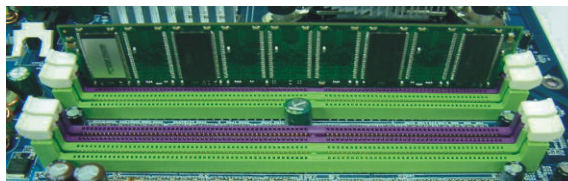

4. Repeat step 1, 2 & 3 for the remaining memory modules.

* The pictures shown above are for reference only. Your mainboard configuration may vary with the pictures shown.

Back Panel Configuration

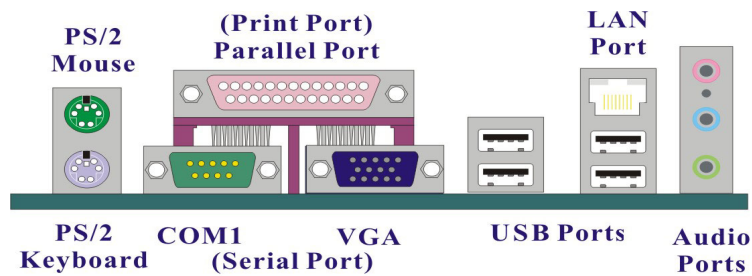

PS/2 Mouse/ Keyboard Connectors: PS2KB/MS

This mainboard provides a standard PS/2 mouse connector and PS/2 Keyboard connector. The pin assignments are described below:

PS/2 Mouse

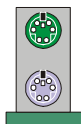

PS/2 Keyboard

Pin	Assignment	Pin	Assignment
1	Data	4	+5 V (fused)
2	No connect	5	Clock
3	Ground	6	No connect

Serial and Parallel Ports

The K8M800-754 mainboard is equipped with one serial port and one parallel port on the back panel. The serial and parallel ports will be explained below:

Parallel Port: PARALLEL

The parallel port on your system has a 25-pin connector and is used to connect parallel printers and other devices which are able to support with this port.

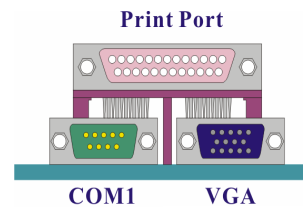

Serial Port: COM1

This mainboard provides a serial port COM1 on the back panel, and is used to connect mice, modems and other peripheral devices. You can also connect your computer to another one through this serial port, in order to transfer data or information from your hard drive disk.

VGA Port: VGA

The K8M800-754 mainboard provides a VGA port for connecting the monitor cables. The D-Sub 15-pin connector is used to connect into this port for monitor displaying.

USB & LAN Ports:

There are four USB 2.0/ 1.1 ports on the back panel. These USB ports are used to connect with USB devices, such as keyboard, mice and other USB supported devices. There is also a 10/100 Mbps LAN port available for you to connect a network.

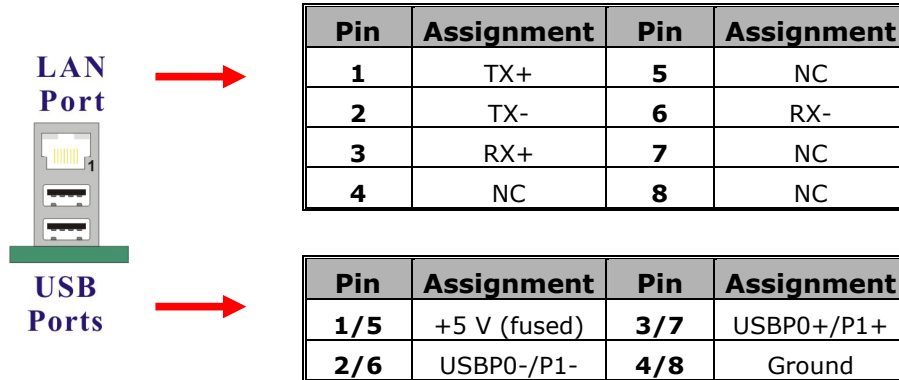

Audio Port Connectors: Sound

This mainboard is equipped with three Audio Ports. The three ports, Mic-in, Line-in and Speaker-out are standard audio ports that provide basic audio functionality. After you install the Super 5.1 Channel drivers and Super 5.1 Audio effects, the three audio ports are enabled and able to support your speakers.

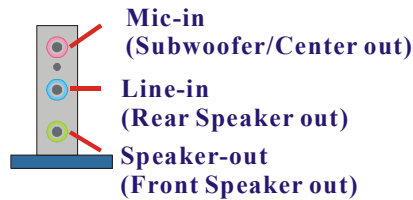

Speaker-Out It is a standard audio port for connecting the speaker or headphone connectors. When the Super 5.1 Channel Audio driver installed and enabled, your front speaker function will be enabled with this port. In addition, if you enable the Super 5.1 Channel Audio Effects but using the Standard 2 channel audio function, we suggest you to connect this port, so that the outputted sounds can be high fidelity.

Line In This port is for connecting an external audio device such as a CD player, tape player or other audio devices that provide an audio input. When the Super 5.1 Channel Audio Effects is enabled, your rear speaker function will be enabled with this port.

Mic In This port is for connecting a microphone to input your voice. When the Super 5.1 Channel Audio Effects is enabled, your subwoofer/center function will be enabled.

This mainboard supports 6-channel audio function (Super 5.1 Channel Audio Effects). See Appendix I for more information.

Front Panel Headers Indication: SW/LED、PWRLED、SPEAKER

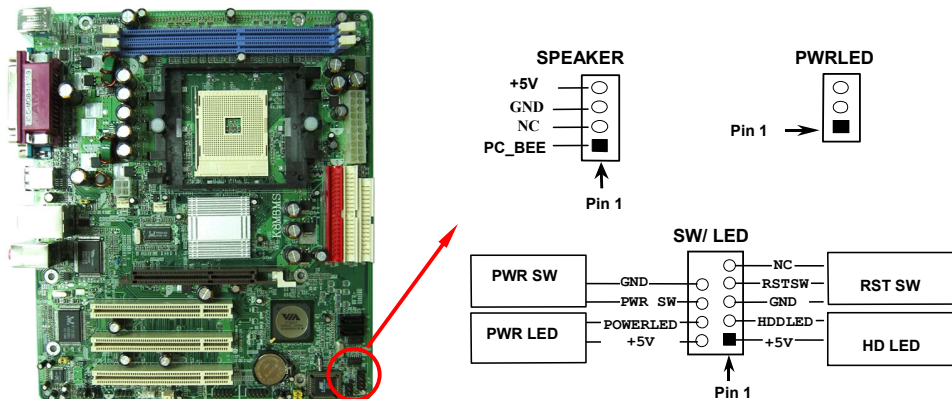

HD LED (Hard Drive LED Header)

This header can be connected to an LED on the front panel of a computer case. The LED will flicker during the drive disk activity. The drive disk activity only applies to those IDE devices directly connected to the mainboard.

RST SW (Reset Switch Header)

This header can be connected to a momentary SPST switch. The switch is normally left open. When the switch closed, it will cause the mainboard to reset and run the POST (Power On Self Test).

PWR SW (Power on Switch Header)

This header can be connected to a front panel power switch. The switch must pull the Power Button pin to ground for at least 50 ms to signal the power supply to switch on or off (the time required is due to internal debounce circuitry on the system board). At least two seconds must pass before the power supply will recognize another on/off signal.

PWR-LED (3-pin Power LED Header)

This mainboard provides a 3-pin power LED header on the front panel of a computer case; connect the 3-pin power LED cable to the header. The LED will illuminate while the computer is powered on.

SPEAKER (Speaker Header)

A front panel speaker can be connected to this header. When you reboot the computer, the speaker will sound a short “beep”. If there is something wrong during the Power On Self-Test, the speaker otherwise will sound “irregular beep” to warn you.

Connectors

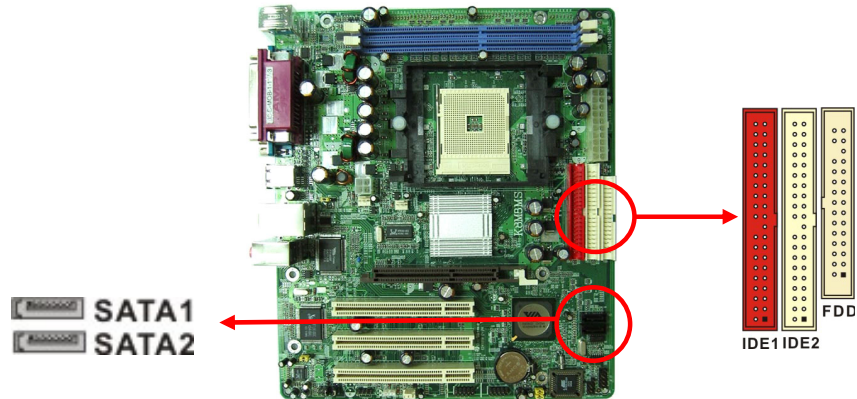

Floppy Drive Connector: FDC

The mainboard provides a standard floppy drive connector (FDC) that supports 360K, 720K, 1.2M, 1.44M and 2.88M floppy disks. This connector supports the floppy drive ribbon cables provided in the packaging.

Hard Drive Connectors: IDE1/ IDE2 、 SATA1/ SATA2

The mainboard has a 32-bit enhanced PCI IDE Controller that supports Ultra ATA 33, Ultra ATA 66, Ultra ATA 100 and Ultra ATA 133. It has two slots, IDE1 and IDE2 for connecting the hard drive disks. You can expand to connect maximal 4 IDE supported devices, such as hard drive disk, CD-ROM, 120MB floppy disk, and so on. The mainboard also has two Serial ATA connectors that support SATA RAID 0 or 1.

IDE1 (Primary IDE Connector)

You can connect up to two hard drive disks to IDE1. If you attach two HDDs, you must use a ribbon cable with three connectors. You must also configure one drive as the master and one drive as the slave.

IDE2 (Secondary IDE Connector)

The IDE2 connector can also support a Master and a Slave HDD. The configuration is similar to IDE1.

SATA1/ SATA2

The SATA connectors support the transfer rate to 150 MB/s and SATA RAID 0 or 1 mode. The connectors only can connect one serial ATA hard disk device of each.



This mainboard supports SATA RAID 0 or 1. See appendix II for more information.

Jumpers & Headers

On-board LAN function Enabled/ Disabled: JP2

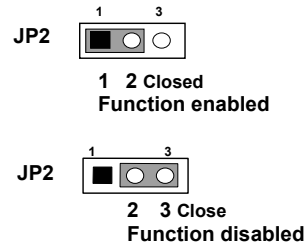
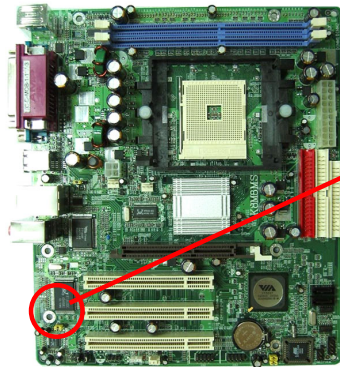

(The word Closed means to put the jumper caps on the header pins.)

USB Power On Function Enabled/ Disabled: JP1, JP3

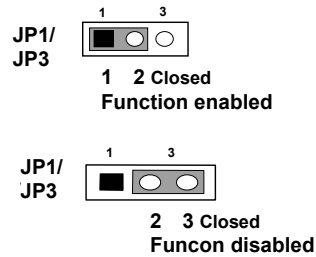
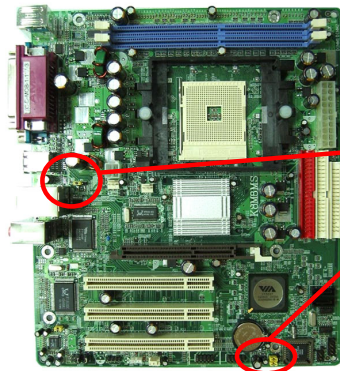

(The word Closed means to put the jumper caps on the header pins.)

USB Port Headers (Optional): USB2/ USB3

An optional USB bracket may be included with this product. The bracket is typical secured to the back side of your computer case and has standard USB ports that you can connect to external USB devices. The bracket will also have cables that you can extend to the USB2 or USB3 headers.

* If you are using USB 2.0 devices with Windows 2000/ XP, you will need to install the USB 2.0 driver from the Microsoft® website.

Clear CMOS Setup: JBAT

The “Clear CMOS” function is used when you cannot boot your system due to some CMOS problems, such as a password is forgotten. This jumper allows you to reset the CMOS configurations, and then reconfigure it.

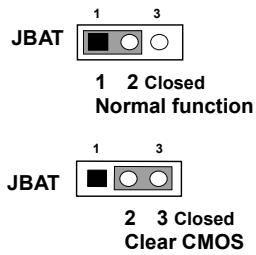
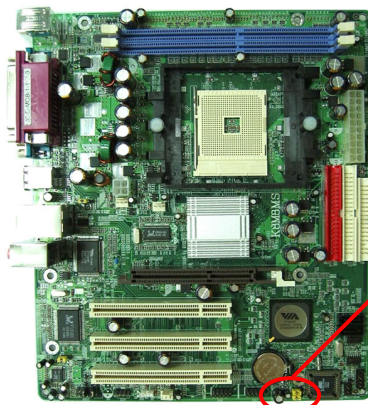

(The wleans to put the jumper caps on the hea pins.)

1.



The following procedures are for resetting the BIOS password. It is important to follow these instructions closely.

1. Turn off your system and disconnect the AC power cable
2. Set JBAT to OFF (2-3 Closed)
3. Wait for several seconds
4. Set JBAT to ON (1-2 closed)
5. Connect the AC power cable and turn on your system
6. Reset a new password

Audio Connectors

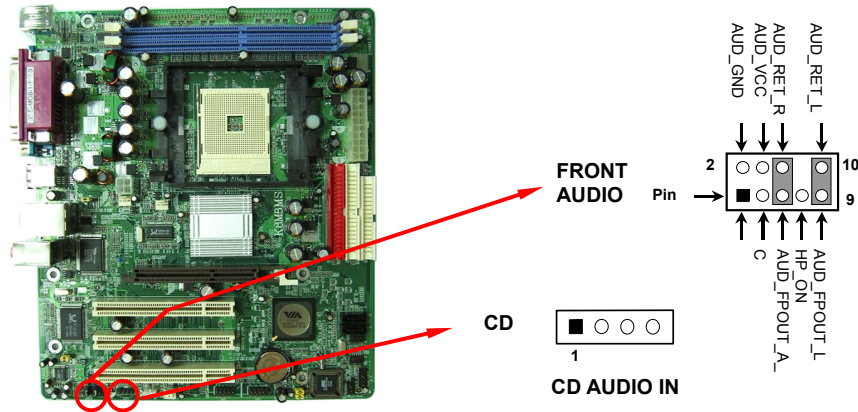

CD-ROM Audio-In Header: CD-IN

This header is used to connect to a CD-ROM / DVD audio cable.

Front Panel Audio Header: FRONT AUDIO

If your computer case has the embedded audio equipment design or you are using an audio bracket (optional). You can attach these components to the FRONT_AUDIO header of the mainboard. First, remove the jumper caps covering the header pins. Connect pin 1, 3 to the case microphone. Connect pin 9 and 5 to the earphone. If you do not intend to use the FRONT_AUDIO panel, do not remove the jumper caps; otherwise, the front panel audio & the back panel audio will disconnect simultaneously.



If the jumper caps are in place, jumper cap 1 is on pin 5 & 6, and jumper cap 2 is on pin 9 & 10. If you do not intend to use the FRONT AUDIO panel, do not remove the jumper caps.

Slots

This mainboard provides one AGP slots and three PCI slots. These slots are designed for expansion cards used, in order to complement and enhance the functionality of the mainboard and your system.

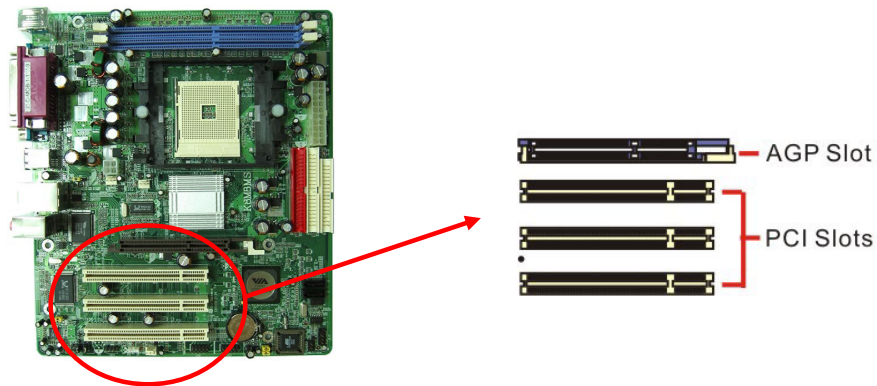

AGP Slot (4X/ 8X): AGP

The mainboard is equipped a 2X/ 4X/ 8X Accelerated Graphics Port (AGP) for working with an VGA card.

PCI Slots: PCI1-6

This mainboard is equipped 6 standard PCI slots. PCI (Peripheral Component Interconnect) slots are the bus standard for setting more expansion cards and also has supplanted the older ISA bus standard.

Power Supply Attachments

ATX Power Connector: ATX_PWR、ATX_12V

This mainboard requires two ATX power connectors, one 20-pin connector and one 4-pin connector. Your power supply must have both two connectors. Connect the 4-pin connector first, and then connect another 20-pin connector. Make sure these connectors are set in secure before applying power.

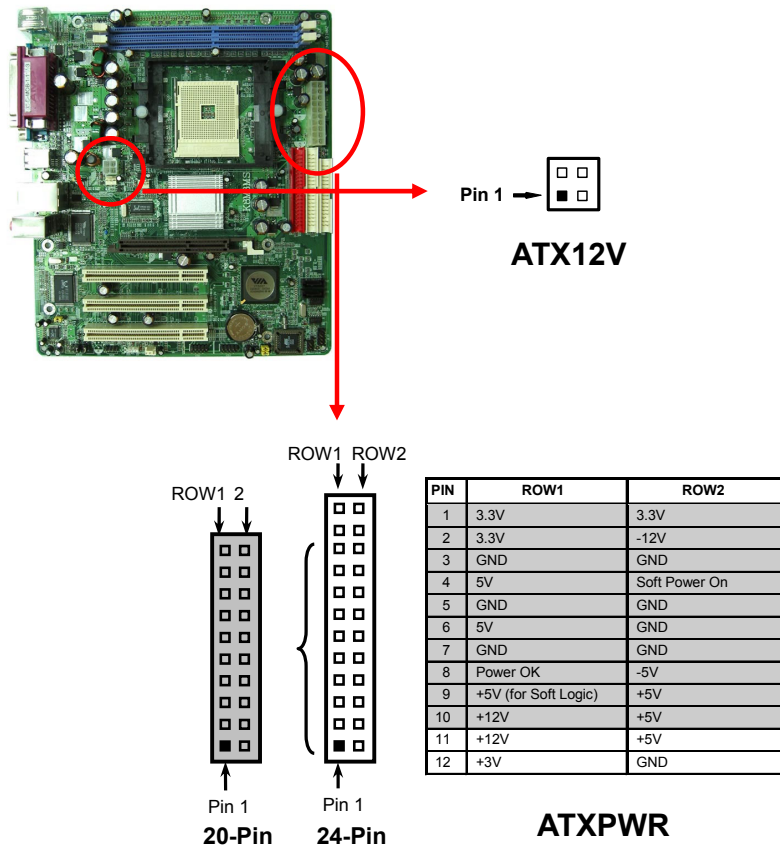

Appendix I: Super 5.1 Channel Audio Effects Setup

1. After into the system, click the audio icon  from the Windows screen.
2. Click Speaker Configuration button, you can see the screen like the picture below.
3. You can choice 2, 4 or 6 channels by your speakers.

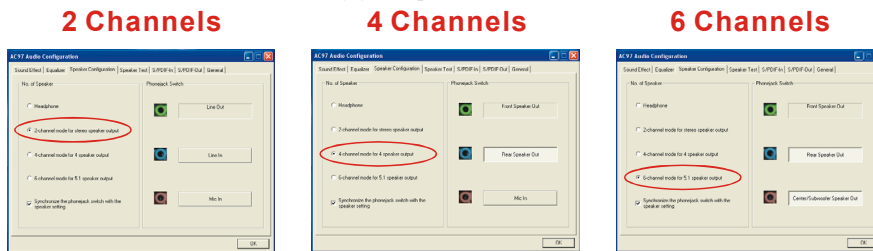

Super 5.1 Channel Audio Effects

This mainboard comes with an ALC655 Codec which supports high quality Super 5.1 Channel audio effects. With ALC655, you are able to use standard line-jacks for surround audio output without connecting to any auxiliary external modules. Using this function, you have to install the audio driver in the bonus Pack CD as well as an audio application supported with the Super 5.1 Channel audio effects. See the audio Port Connectors in the Hardware Installation section for a description of the output connectors.

Speaker Test

Make sure the cable is firmly into the connector.

1. Click the audio icon  from the Windows screen.
2. Click Speaker Test button, you can see the screen like the pictures below.
3. Select the speaker which you want to test by clicking on it.



Appendix II: SATA RAID 0/1 **Specification**

Introduction to RAID

(Redundant Array of Independent Disks)

RAID technology is a sophisticated disk management system that manages multiple disk drives, enhancing I/O performance and providing redundancy in order to prevent the loss of data in case any of the individual disks fail. The SATA RAID facility on this board provides RAID 0 (striped) and RAID 1 (mirrored).

Disk Striping (RAID 0)

Striping is a performance-oriented, non-redundant disk storage technology. With RAID striping, multiple disks are used to form a larger virtual disk. Data is then striped or mapped across all the physical disks. In this way modern SATA and ATA bus mastering technology can be used to perform multiple I/O operations in parallel, enhancing performance. While Striping is discussed as a RAID Set type, it actually does not provide fault tolerance.

Disk Mirroring (RAID 1)

With Disk Mirroring there is a redundant disk that mirrors the main disk. Data that is written to the main disk is also written to the redundant disk. This redundancy provides fault tolerant protection from a single disk failure. If a read/write failure occurs on one drive, the system can still read and write data using the other drive.